COMPOSITE SLABS AND BEAMS USING STEEL DECKING: BEST PRACTICE FOR DESIGN AND CONSTRUCTION



THE METAL CLADDING & ROOFING MANUFACTURERS ASSOCIATION

in partnership with

THE STEEL CONSTRUCTION INSTITUTE

© 2009 The Steel Construction Institute and The Metal Cladding & Roofing Manufacturers Association

Apart from any fair dealing for the purposes of research or private study or criticism or review, as permitted under the Copyright Designs and Patents Act, 1988, this publication may not be reproduced, stored or transmitted, in any form or by any means, without the prior permission in writing of the publishers, or in the case of reprographic reproduction only in accordance with the terms of the licences issued by the UK Copyright Licensing Agency, or in accordance with the terms of licences issued by the appropriate Reproduction Rights Organisation outside the UK.

Enquiries concerning reproduction outside the terms stated here should be sent to the publishers, The Steel Construction Institute, at the address given on the inside cover page.

Although care has been taken to ensure, to the best of our knowledge, that all data and information contained herein are accurate to the extent that they relate to either matters of fact or accepted practice or matters of opinion at the time of publication, The Steel Construction Institute, The Metal Cladding & Roofing Manufacturers Association, the authors and the reviewers assume no responsibility for any errors in or misinterpretations of such data and/or information or any loss or damage arising from or related to their use.

Publications supplied to the Members of the Institute at a discount are not for resale by them.

Publication Number: MCRMA Technical Paper No 13; SCI P300 Revised Edition

ISBN 978-1-85942-184-0 .

A catalogue record for this book is available from the British Library.



Steel Knowledge

SCI (The Steel Construction Institute) is the leading, independent provider of technical expertise and disseminator of best practice to the steel construction sector. We work in partnership with clients, members and industry peers to help build businesses and provide competitive advantage through the commercial application of our knowledge. We are committed to offering and promoting sustainable and environmentally responsible solutions.

Our service spans the following five areas:

Membership

- Individual and corporate membership
- Technical information
- Courses and Education
- Publications
- Online reference tools
- Codes and standards

Construction solutions

- Sustainability
- Product development
- Research
- Engineering solutions

Communications technology

- Websites
- Communities
- Design tools

Assessment

- SCI assessed

The Steel Construction Institute
Silwood Park, Ascot, Berkshire, SL5 7QN.
Telephone: +44 (0) 1344 636525
Fax: +44 (0) 1344 636570
Email: membership@steel-sci.com

World Wide Web site: <http://www.steel-sci.org>



The Metal Cladding and Roofing Manufacturers Association represents the major manufacturers in the metal roofing and cladding industry and seeks to foster and develop a better understanding amongst specifiers and end users alike of the most effective use of metal building products, components and systems.

From its inception, MCRMA has been the leading voice for the industry and works closely with a variety of industry bodies and standards committees to ensure that best practice is followed at all times. The Association's campaign for improved technical knowledge of metal building construction within the industry is borne out by its well established and authoritative series of technical design guides which are all freely available on the MCRMA web site to ensure the widest dissemination of good practice.

The environmental and sustainable benefits of metal, together with developments in colour and form have led to a much wider use of metal in construction. MCRMA is committed to remaining at the forefront of developments in metal building technology to ensure that specifiers have the opportunity to create imaginative and innovative building designs that offer both cost-effective and sustainable solutions to benefit future generations.

The Metal Cladding And Roofing Manufacturers Association Limited
18 Mere Farm Road, Prenton, Wirral, Cheshire CH43 9TT
Tel: +44 (0) 151 652 3846
Fax: + 44 (0) 151 653 4080

www.mcrma.co.uk

MCRMA Technical Paper No. 13
SCI Publication No. P300

Composite Slabs and Beams using Steel Decking: Best Practice for Design and Construction (Revised Edition)

J W Rackham BSc (Build Eng), MSc, DIC, PhD, CEng, MICE

G H Couchman MA, PhD, CEng, MICE

S J Hicks B Eng, PhD (Cantab)

Published by:
The Metal Cladding & Roofing Manufacturers Association
in partnership with
The Steel Construction Institute

FOREWORD

Composite construction has proven popular because it combines structural efficiency with speed of construction to offer an economic solution for a wide range of building types. Applications include commercial, industrial and residential buildings.

This guide covers the design and construction of composite slabs and beams, and addresses the good practice aspects of these activities. It updates the previous MCRMA/SCI guide, which was published in 2000. The update reflects the latest guidance for good practice and gives information on design to the Eurocodes, but omits most of the advice given previously on construction practice for decking, as this is now covered comprehensively in separate BCSA documents *Guide to the installation of deep decking, Publication No. 44/07*, and *Code of Practice for metal decking and studwelding, Publication No. 37/04*.

Design and construction guidance related to *Slimdek* construction is dealt with in a separate part of the guide because of the significant number of differences from 'traditional' composite beam and slab construction.

The principal authors of this publication were Dr J W Rackham, Dr G H Couchman, and Dr S J Hicks (all from The Steel Construction Institute). They were part of a collaborative group responsible for the content of the publication, other members of which were:

Mr A J Shepherd	Richard Lees Steel Decking Ltd
Mr J Turner	Structural Metal Decks Ltd
Mr A Wallwork	Corus Panels and Profiles Ltd
Mr D St Quinton	Kingspan Structural Products Ltd
Mr D Mullett	Studwelders Ltd
Mr D E Simpson	The Concrete Society

Further information was provided by Dr W I Simms and Mr A Way, both from The Steel Construction Institute.

The preparation of this document was funded and commissioned by the Metal Cladding and Roofing Manufacturers Association (MCRMA).

CONTENTS

	Page No.
FOREWORD	iii
SUMMARY	vi
1 INTRODUCTION	1
1.1 Benefits of composite construction	2
1.2 Applications	3
1.3 Scope of this publication	3
2 THE DESIGN AND CONSTRUCTION TEAM	4
2.1 Team members	4
2.2 Roles in design and construction	5
2.3 Design and construction sequences	8
3 INFORMATION TRANSFER	10
3.1 Design stage	10
3.2 Construction stage	11
4 DESIGN OF DECKING AND SLABS	15
4.1 Steel decking	15
4.2 Composite slabs	26
4.3 Acoustic insulation	48
4.4 Health & Safety	51
4.5 Further reading	52
5 DESIGN OF COMPOSITE BEAMS	54
5.1 Construction stage	55
5.2 Composite stage	56
5.3 Shear connection	63
5.4 Further reading	72
6 CONSTRUCTION PRACTICE - CONCRETE	75
6.1 Concrete supply design	75
6.2 Placing concrete	76
6.3 Loads on the slab during and after concreting	81
6.4 Further reading	83
7 SLIM FLOOR CONSTRUCTION	85
7.1 Introduction	85
7.2 Design	88
7.3 Construction practice	100
7.4 Further reading	104
8 REFERENCES	105

SUMMARY

This guide covers the design and construction of composite floors, paying particular attention to the good practice aspects. Following a description of the benefits of composite construction and its common applications, the roles and responsibilities of the parties involved in the design and construction process are identified. The requirements for the transfer of information throughout the design and construction process are described.

The design of composite slabs and beams is discussed in detail in relation to the Eurocodes and BS 5950. In addition to general ultimate and serviceability limit state design issues, practical design considerations such as the formation of holes in the slab, support details, fire protection, and attachments to the slab are discussed. Guidance is also given on the acoustic performance of typical composite slabs. The obligations of designers according to the CDM Regulations are identified and discussed.

The practical application of *Slimdek* construction, which normally utilises deep decking and special support beams, is also covered. Typical construction details are illustrated, and guidance is given on the formation of openings in the beams and the slab.

1 INTRODUCTION

Composite slabs consist of profiled steel decking with an in-situ reinforced concrete topping. The decking not only acts as permanent formwork to the concrete, but also provides sufficient shear bond with the concrete so that, when the concrete has gained strength, the two materials act together compositely.

Composite beams are normally hot rolled or fabricated steel sections that act compositely with the slab. The composite interaction is achieved by the attachment of shear connectors to the top flange of the beam. These connectors generally take the form of headed studs. It is standard practice in the UK for the studs to be welded to the beam through the decking (known as 'thru-deck' welding) prior to placing the concrete. The shear connectors provide sufficient longitudinal shear connection between the beam and the concrete so that they act together structurally.

Composite slabs and beams are commonly used (with steel columns) in the commercial, industrial, leisure, health and residential building sectors due to the speed of construction and general structural economy that can be achieved. Although most commonly used on steel framed buildings, composite slabs may also be supported off masonry or concrete components.

A typical example of the decking layout for a composite floor is shown in Figure 1.1. The lines of shear connectors indicate the positions of the composite beams.



Figure 1.1 *A typical example of composite floor construction, showing decking placed on a steel frame*

1.1 Benefits of composite construction

Composite construction has contributed significantly to the dominance of steel frames in the commercial building sector in the UK. The main benefits of composite construction are:

Speed of construction

Bundles of decking can be positioned on the structure by crane and the individual sheets then installed by hand. Using this process, crane time is minimal, and in excess of 400 m² of decking can be installed by one team in a day, depending on the shape and size of the building footprint. The use of the decking as a working platform speeds up the construction process for following trades. Minimal reinforcement is required, and large areas of floor can be poured quickly. Floors can be concreted in rapid succession. The use of fibre reinforced concrete can further reduce the programme, as the reinforcement installation period is significantly reduced.

Safe method of construction

The decking can provide a safe working platform and act as a safety ‘canopy’ to protect workers below from falling objects.

Saving in weight

Composite construction is considerably stiffer and stronger than many other floor systems, so the weight and size of the primary structure can be reduced. Consequently, foundation sizes can also be reduced.

Saving in transport

Decking is light and is delivered in pre-cut lengths that are tightly packed into bundles. Typically, one lorry can transport in excess of 1000 m² of decking. Therefore, a smaller number of deliveries are required when compared to other forms of construction.

Structural stability

The decking can act as an effective lateral restraint for the beams, provided that the decking fixings have been designed to carry the necessary loads and specified accordingly. The decking may also be designed to act as a large floor diaphragm to redistribute wind loads in the construction stage, and the composite slab can act as a diaphragm in the completed structure. The floor construction is robust due to the continuity achieved between the decking, reinforcement, concrete and primary structure.

Shallower construction

The stiffness and bending resistance of composite beams means that shallower floors can be achieved than in non-composite construction. This may lead to smaller storey heights, more room to accommodate services in a limited ceiling to floor zone, or more storeys for the same overall height. This is especially true for slim floor construction, whereby the beam depth is contained within the slab depth (see Section 7).

Sustainability

Steel has the ability to be recycled repeatedly without reducing its inherent properties. This makes steel framed composite construction a sustainable solution. ‘Sustainability’ is a key factor for clients, and at least 94% of all steel construction products can be either re-used or recycled upon demolition of a

building. Further information on sustainability of composite flooring systems is given in *Composite Flooring Systems: Sustainable construction solutions*^[1].

Easy installation of services

Cable trays and pipes can be hung from hangers that are attached using special ‘dovetail’ recesses rolled into the decking profile, thereby facilitating the installation of services such as electricity, telephone and information technology network cabling. These hangers also allow for convenient installation of false ceilings and ventilation equipment (see Section 4.2.8).

The above advantages (detailed in more depth in SCI publication *Better Value in Steel: Composite flooring*^[2]) often lead to a saving in cost over other systems. SCI publication *Comparative structure cost of modern commercial buildings*^[3] shows solutions involving composite construction to be more economical than steel or concrete alternatives for both a conventional four storey office block and an eight storey prestigious office block with an atrium.

1.2 Applications

Composite slabs have traditionally found their greatest application in steel-framed office buildings, but they are also appropriate for the following types of building:

- Other commercial buildings
- Industrial buildings and warehouses
- Leisure buildings
- Stadia
- Hospitals
- Schools
- Cinemas
- Housing; both individual houses and residential buildings
- Refurbishment projects.

1.3 Scope of this publication

This publication gives guidance on the design and construction of composite slabs and composite beams in order to disseminate all the relevant information to the wide and varied audience involved in the design and construction chain. Guidance is given on design and construction responsibilities, and requirements for the effective communication of information between the different parties are discussed.

The principal aim of the design guidance given in this publication is to identify relevant issues. The reader is directed elsewhere, including to British Standards and Eurocodes, for specific design guidance. Summary boxes are used to highlight how to achieve economic, buildable structures through good practice in design.

2 THE DESIGN AND CONSTRUCTION TEAM

The aim of this Section is to identify typical activities and responsibilities for the team members involved in the design and construction of a building using composite components. Clearly, the precise delegation of responsibilities will depend on the details of the contract for a specific project, with which all parties need to be familiar.

As an overriding principle, the CDM Regulations^[4] state that ‘Every person on whom a duty is placed by these Regulations in relation to the design, planning and preparation of a project shall take account of the general principles of prevention in the performance of those duties during all stages of the project’.

A similar requirement applies for the responsibilities during construction: ‘*Every person on whom a duty is placed by these Regulations in relation to the construction phase of the project shall ensure as far as is reasonably practicable that the general principles of prevention are applied in the carrying out of the construction work*’. Guidance on the specific details of the responsibilities of each of the relevant parties under the CDM Regulations may be found in Reference 5.

2.1 Team members

In recognition of the different types of contract that may be employed, the following generic terminology has been adopted for the key parties involved:

The ***Client*** is the person (or organisation) procuring the building from those who are supplying the components and building it.

The ***Architect*** is the person (or practice) with responsibility for the integration of the overall design of the building, and with a particular responsibility for the building function and aesthetics.

The ***Structural Designer*** is the person (or organisation) who is responsible for the design of the structural aspects of the permanent works. This role could, for example, be fulfilled by a Consultant, a ‘Design and Build’ Contractor, or a Steelwork Sub-contractor. In many cases the Structural Designer will delegate some of the design responsibility. For example, a Consultant may effectively delegate some of the design work by using data supplied by a decking manufacturer. The manufacturer then becomes a Delegated Designer, with responsibility for certain aspects of the decking and, perhaps, the slab design. Where applicable, this must be clearly communicated to the manufacturer along with all relevant design information required early in the project design process.

A ***Delegated Designer*** is a person (or organisation) who, because of specialist knowledge, carries out some of the design work on behalf of the Structural Designer. This may be achieved by supplying design information such as load-span tables for composite slabs.

The ***Main Contractor*** is the organisation responsible for the building of the permanent works, and any associated temporary works.

The *CDM co-ordinator* has obligations with regard to the safety aspects of a project. This is a role defined in the CDM Regulations (see Section 2.2, Safety).

2.2 Roles in design and construction

Form of floor construction

The choice of floor construction and the general beam and column arrangements are the responsibility of the Architect and the Structural Designer. The Architect will be concerned with more general and spatial aspects of the building form, such as the column locations, the construction depth of the floors, and the soffit appearance (if it is to be exposed).

The Structural Designer will determine the general loads to be considered in the design of the structure, based on the type of occupancy for each area specified by the Architect/Client. Details of any specific loads, for example due to services, may need to be supplied by others. The Structural Designer will also undertake scheme designs to identify beam and slab solutions with spanning capabilities to suit the Architect's requirements.

Composite beams

The detailed design of the composite beams (Section 5) is the responsibility of the Structural Designer, who should recognise that there is an interaction between the beam and slab design, particularly with the decking and transverse reinforcement. In designing the composite beams, due consideration should be given to the construction stage load case.

Although it may be necessary to consult the decking manufacturer for practical advice on shear connector configurations, it is the responsibility of the structural designer to specify the shear connector type and quantities required.

When considering composite beams, the designer should be aware of practical considerations such as the access requirements for using stud welding equipment (see Section 5.3.1) and minimum practical flange widths for sufficient bearing of the decking (see Section 4.1.4). These requirements may have serious implications on the economy of the chosen solution.

Composite slab

The design of the composite slab (Section 4) is the responsibility of the Structural Designer. Particular attention should be paid to areas where there are special loads, such as vehicle loads and loads from solid partitions and tanks. Construction stage loads should also be considered, with particular attention to any concentrated loads from plant or machinery required to carry out the safe erection of the building and its structure. When designing and detailing any reinforcement, the Structural Designer should ensure that the specified bars can be located within the available depth of slab and that the correct reinforcement covers for the design durability conditions can be achieved. (Recognise any other space constraints that may exist on site.)

It is recommended that the Structural Designer prepares general arrangement drawings for the slab (in addition to the steelwork general arrangement drawings). In particular, these drawings should define the edges and thickness of the slab, and they should form the basis of the decking layout drawings and the reinforcement drawings.

The Structural Designer should also produce a reinforcement layout drawing for each bay of each floor. The reinforcement grade, location, lengths, minimum overlaps and minimum concrete cover should be shown (and appropriate information about fibres if they are to be used). On site, these drawings will be used to check that all the reinforcement has been fixed correctly (or fibres correctly incorporated).

Designing a concrete mix to provide the required structural and durability performance is normally the responsibility of the Main Contractor.

Choice of Decking

The choice of decking and its general arrangement is the responsibility of the Structural Designer. The design must consider the fire resistance of the slab (which may depend on the decking type), the ability of the decking and composite slab to resist the applied loading, the propping requirements, and the deflections at both the construction and in-service (composite) stages. As well as influencing all of these, the choice of decking profile may have implications for the composite beam design.

Design data provided by a decking manufacturer will normally be used to select the decking, as its performance is complex and is best determined from tests. The Structural Designer must be satisfied with the information supplied in this form by the Delegated Designer (decking supplier/manufacturer), and ensure that it is not used 'out of context'. Consultation with the decking supplier/manufacturer is recommended if there is any doubt. Where decking is specified for unusual applications, the 'standard' design information may not be directly applicable (see Section 4).

Decking arrangement and details

The decking layout drawings (Section 3.2) are normally prepared by a decking sub-contractor acting as a Delegated Designer. Details should be checked by the Structural Designer, who should advise the Delegated Designer of any special requirements, such as the need for extra fixings when the decking is required to act as a wind diaphragm, or of any particular requirements concerning the construction sequence. The Structural Designer should check that the proposed bearing details and the interfaces with the other elements of construction are practicable, and that they permit a logical, buildable sequence.

In preparing the decking layout drawings, the decking sub-contractor may find it beneficial to refine the design. For example, it may be necessary to change some of the continuous spans to simple spans for practical reasons. This may have implications on the propping requirements during construction.

The loads that may be applied to the decking in the construction condition, both as a temporary working platform and as formwork, should be clearly indicated on the decking layout drawings or general notes. The loads that may be applied to the composite slab should also be shown on the decking layout drawings, and on the appropriate concreting drawings (these will be included in the Health and Safety File for reference throughout the lifetime of the building). It is therefore essential that all loading assumptions and design criteria are communicated to the decking sub-contractor.

Temporary works

Propping should be avoided wherever possible, as it reduces the speed of construction and therefore affects the construction sequence and economy. When

propping is unavoidable, it is usually necessary to prop through several floors to support the prop loads. This can prevent other operations over a large area. However, when the construction sequence permits, propping does increase the spanning capability of the decking. Determining the propping requirements is generally the responsibility of the Structural Designer (normally using information supplied by a Delegated Designer), although local propping needs may change when the Delegated Designer details the decking layout. The decking should be checked by the Structural Designer to ensure that it can withstand the concentrated loads from the propping arrangement.

The location of lines of props or other temporary supports should be shown on the decking layout drawings. The design and installation of the propping system is the responsibility of the Main Contractor, but propping systems should be braced appropriately. Removal of props should not be carried out before the concrete has reached its specified strength, or, when specified in the contract, before the Structural Designer gives explicit approval.

In addition, the Structural Designer should supply the Main Contractor with the propping loads, and the dead load that has been considered, to help him/her to draw up the propping scheme. When devising the scheme, consideration must be given to the fact that floors will need to be designed to carry the concentrated loads from props (see Section 6 for advice on possible loading). Further advice on propping is given in Section 4.2.7.

Fire protection

The Architect is normally responsible for determining the fire resistance period required for the building, and for choosing the type of fire protection. The Structural Designer, in many cases represented by a Delegated Designer (specialist sub-contractor), is responsible for the specific details of the fire protection. The Structural Designer should also make it clear on the drawings when any voids between the profiled decking and the steel beams have to be filled (see Section 5.2.3).

Safety

Whilst all parties involved in the design and construction process are required to consider construction safety, the CDM co-ordinator has some specific obligations under the CDM Regulations^[4,5]. [It is to be noted that the post of Planning Supervisor established under the previous Regulations has been revoked and replaced by the post of CDM co-ordinator.] These obligations include the creation of the Health & Safety Plan and the Health & Safety File. The aim of the first of these documents is to inform others of potential health and safety issues; the Structural Designer should supply, for example, details of any risks that may be foreseen during construction for inclusion in this plan. The Health and Safety File is intended to assist persons undertaking maintenance work, and will include information such as as-built drawings. The Structural Designer should inform the contractor of any 'residual hazards' (those that the contractor will manage during the construction) associated with any unorthodox method of construction, and the provisions made to help the contractor to manage them. It is the CDM Co-ordinator's responsibility to provide advice and assistance, to ensure that designers fulfil their obligations, to consider health and safety issues, to co-operate with others, and to supply all appropriate information.

2.3 Design and construction sequences

The following flowcharts describe typical design (Figure 2.1) and construction (Figure 2.2) sequences for composite floor construction.

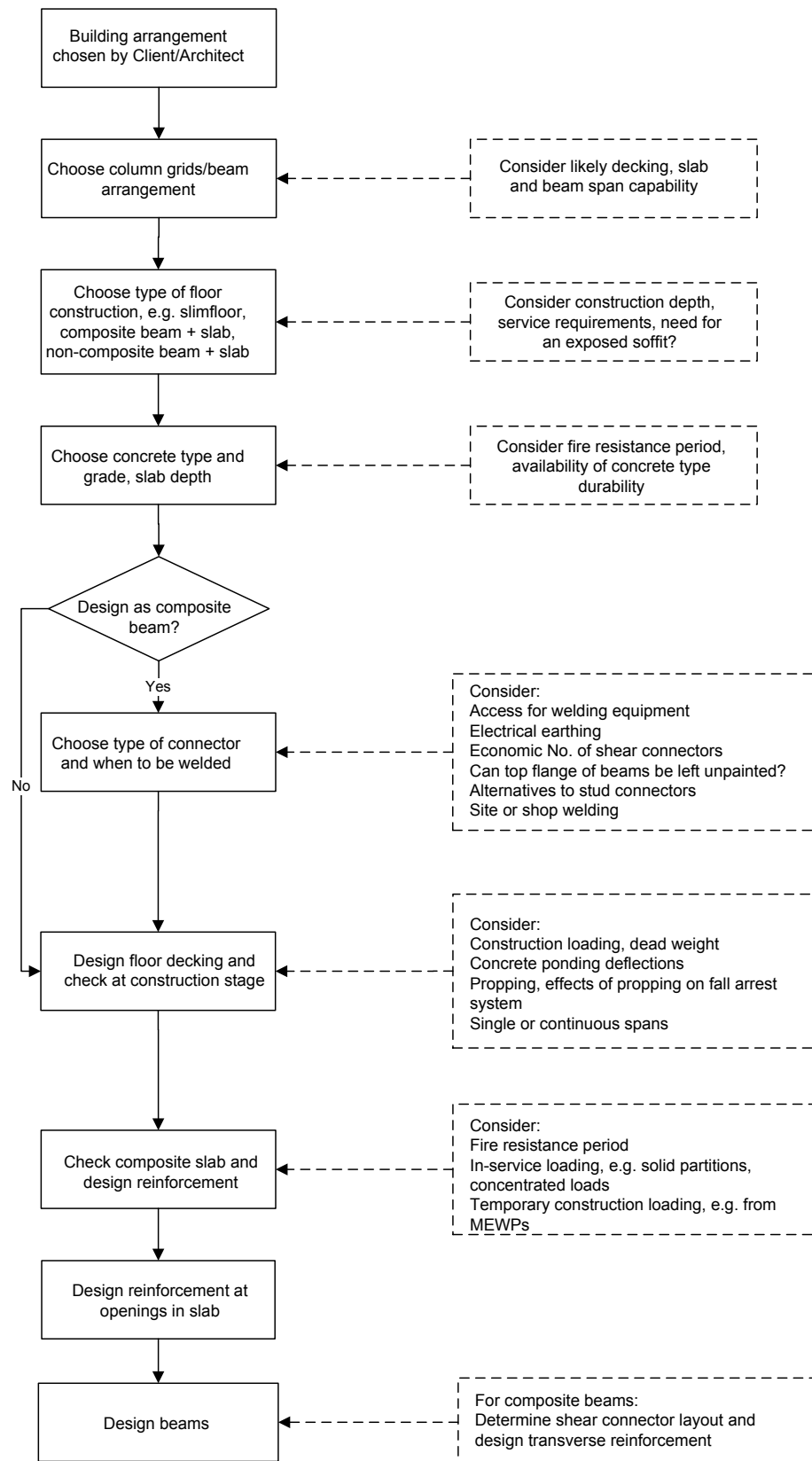

Figure 2.1 Sequence of design activities

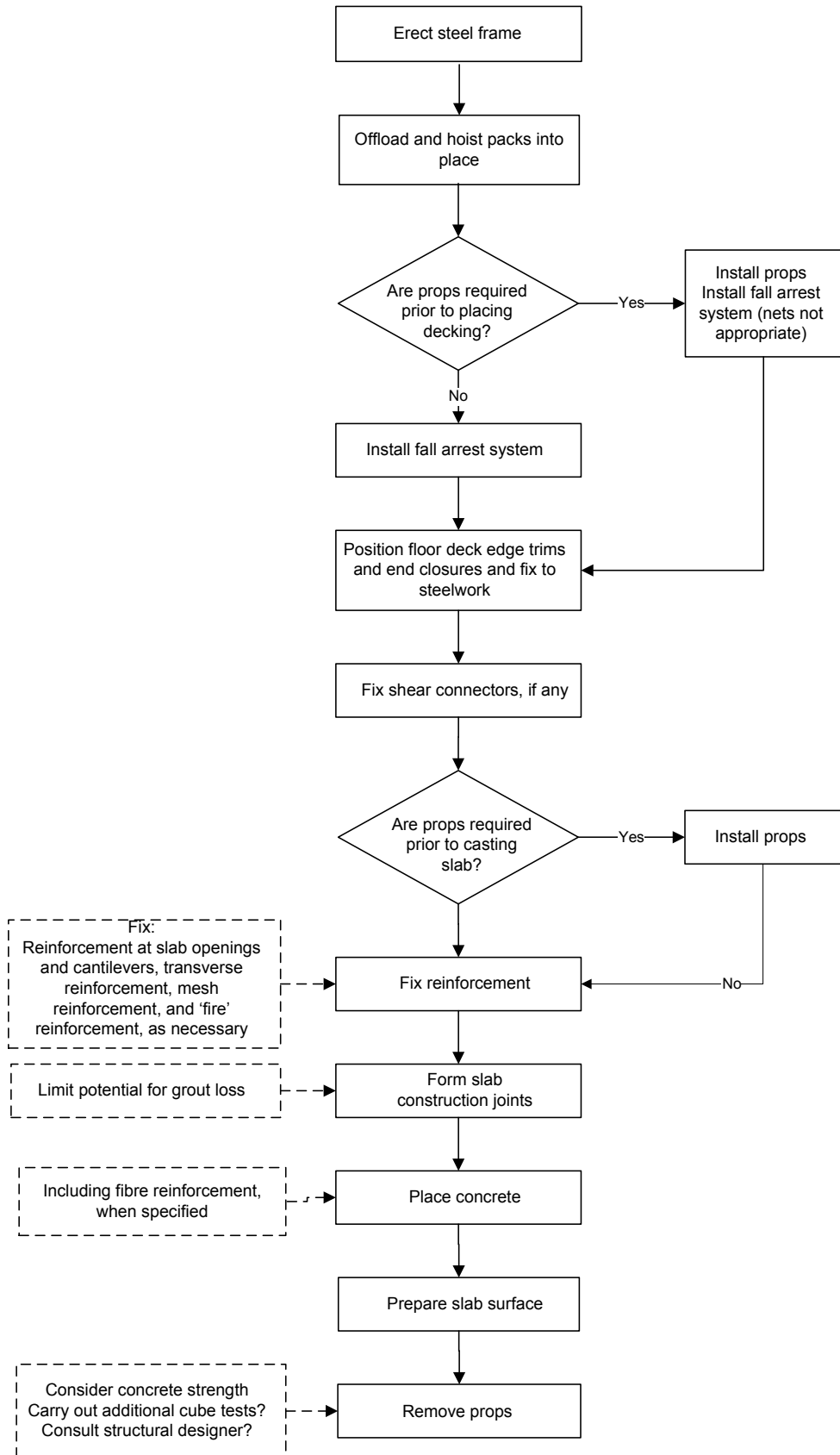

Figure 2.2 *Sequence of construction activities*

3 INFORMATION TRANSFER

Clear and timely communication of information is important given that several parties are involved in the building design process (see Section 2 for identification of typical responsibilities). There are also obligations placed on the key parties under the CDM Regulations^[4] to exchange information during both design and construction.

3.1 Design stage

The design of composite beams and slabs is clearly influenced by spanning requirements, and the loads that are to be supported. In addition to grid layouts, it is therefore important that accurate details of all the loads are established at an early stage. Unfortunately, some information, such as the loads due to the services, is often unavailable when needed, and the Structural Designer has to use conservative values in order to give flexibility when the services are designed at a later stage.

Knowledge of the position of services is also important, because it enables account to be taken of any opening requirements in the beam webs and/or slabs. Openings can have a significant effect on the resistance of a member.

The following list is a guide to the information required to design the composite slabs and beams:

- Column grid and beam general arrangement
- Position of slab edges
- Static and dynamic imposed loads (to include consideration of any temporary concentrated loads from plant/machinery that may be required during construction)
- Services and finishes loads
- Special loads (e.g. walls, wind diaphragm loads)
- Fire resistance period
- Decking type (shallow or deep, re-entrant or trapezoidal)
- Slab depth limitations
- Minimum mass requirements (for acoustic performance)
- Location of openings
- Requirements for soffit appearance and general exposure
- Requirements for service fixings
- Requirements for cladding attachments (which may affect the slab edge detailing)
- Construction tolerances
- Deflection limits
- Propping requirements or restrictions
- Any known site restrictions on the use of thru-deck welding.

In order to prepare the decking layout drawings, a Delegated Designer will also need to know the:

- Concrete type and grade
- Shear connector layout and details
- Cladding support method (for edge trim design, etc.)

There are also specific issues of information transfer that arise because the design of the decking and composite slabs often relies on the use of information presented in decking manufacturers' literature. It is important that the tabulated data and explanatory information is comprehensive. For example, in load-span tables the following points should be clear:

- Are the loads that are given nominal values or design values?
- What allowances, if any, have been made for services loads etc.?
- What fire performance do the tables relate to?
- Do specified reinforcement requirements imply any crack control capability?
- Do the tables imply adequate serviceability behaviour as well as resistance, and if so what limiting criteria have been assumed?

If the Structural Designer chooses to delegate some of the slab design to the design service of a decking manufacturer (Delegated Designer), it is essential that there is clear communication of all relevant design information.

3.2 Construction stage

An absence of essential information transfer between the design and construction teams can lead to delays or, at worst, incorrect or unsafe construction.

The site personnel should check the information provided and confirm that it is complete, passing any relevant information to appropriate sub-contractors. Any variations on site that might affect the design should be referred to the Structural Designer.

Decking layout drawing

Decking layout drawings should be available for those lifting the decking, so that the bundles can be positioned correctly around the frame. Clearly, they should also be available for the deck laying team.

Although different decking contractors' drawing details may vary slightly, the drawings should show (in principle) each floor divided into bays, where a bay is an area that is to be laid from a bundle as one unit. Bays are normally indicated on the drawing using a diagonal line. The number of sheets and their length should be written against the diagonal line. The bundle reference may also be detailed against this diagonal line. Further construction notes for the bay can be referenced using numbers in circles drawn on the diagonal lines, as shown in Figure 3.1. This figure shows an example of a decking layout drawing, but with the shear connectors and fastener information omitted for clarity. Decking contractors' literature should be referenced for exact details.

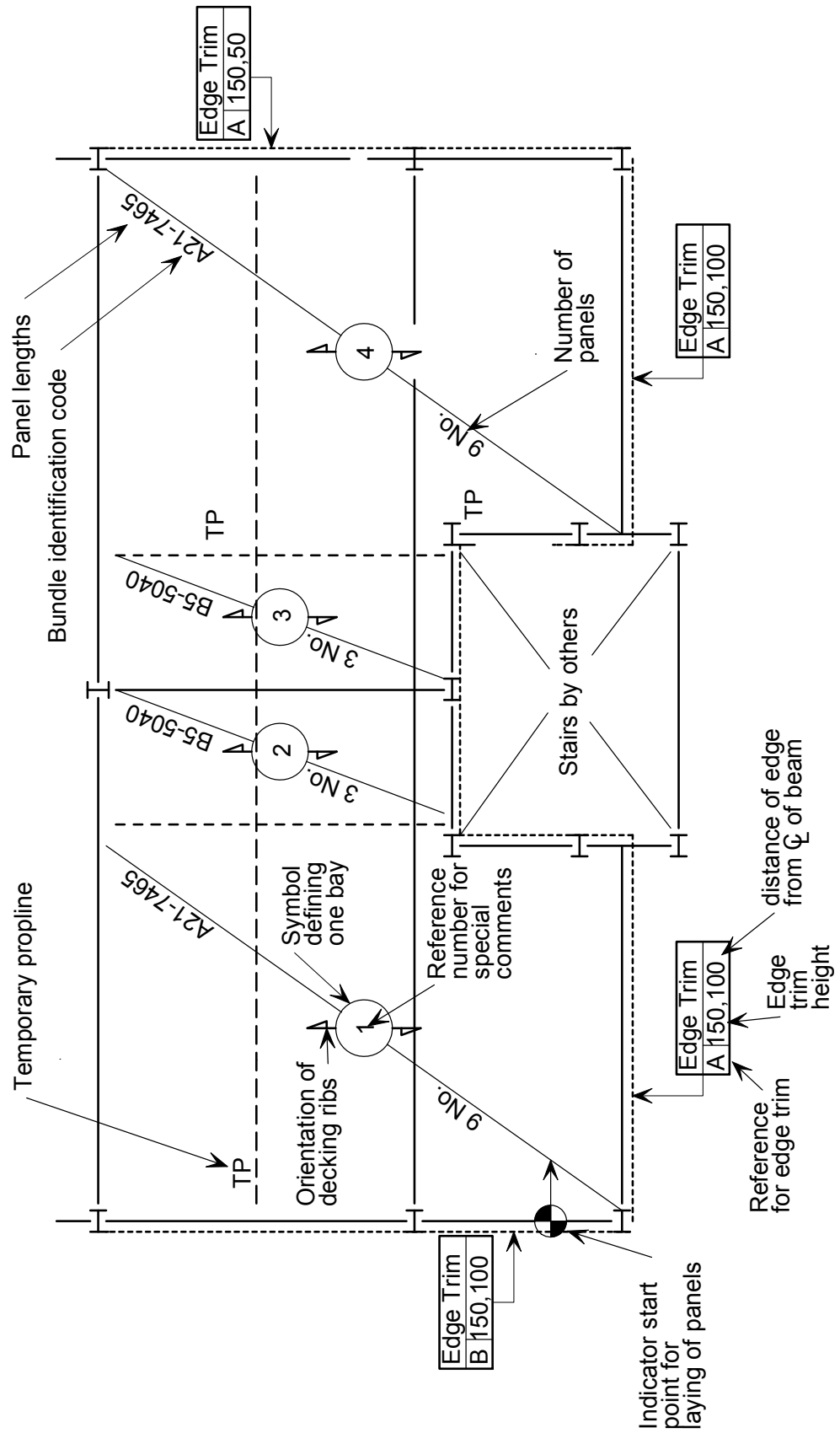

Figure 3.1 Typical decking layout drawing (shear connector and fastener information omitted)

The approximate starting point for laying the decking should be given on the drawings, together with the direction in which laying should proceed. All supports (permanent or temporary) should be identified, and whether they should be in place prior to laying the decking. The letters TP on the drawings typically indicate lines of propping. Column positions and their orientation should also be shown. The decking type, thickness and material strength should be indicated on the drawing.

The location of all openings trimmed with steelwork, and all slab perimeters, should be given relative to the permanent supports. This may be in the form of a reference box titled 'Edge Trim', with a reference number (for details shown elsewhere), the slab depth, and the distance from the edge of the slab to the centre line of the nearest permanent support, but decking contractors' literature should be referred to for the exact drawing details.

The shear connector layout should also be shown on the decking drawings, or on separate drawings for reasons of clarity. The information should include the type of shear connector, its length, orientation (if shot-fired) and position relative to the ribs. The minimum distance between the centre-line of the shear connector and the edge of the decking should be given. Details of preparation, fixing and testing of shear connectors should be available on site. For more information on shear connection, refer to Sections 5.3 and BCSA publication 37/04^[6]

Fastener information should be given on the drawings. The fastener type for both seams and supports should be given, along with maximum spacings (or minimum number of fasteners per metre). Where the Structural Designer has designed the decking to act as an effective lateral restraint to the beams and additional fasteners to the manufacturer's normal fixing arrangement are necessary, this should be clearly indicated on the decking layout drawing and/or general notes.

The general notes should include the design loads that the decking can support in the construction condition. Guidance on avoidance of overload prior to placing the concrete is given in the BCSA publication 37/04^[6].

A copy of the decking layout drawings must be given to the Main Contractor so that checks can be made that the necessary propping is in place. The Main Contractor will also need to refer to these drawings for details of the maximum construction loading and any special loading.

Decking bundle identification

An identification tag should be attached to each bundle of decking delivered to site. The tag will normally contain the following information:

- Number of sheets, their lengths and thickness
- Total bundle weight
- Location of floor to receive bundle
- Deck type
- Bundle identification.

Product information on the decking should also be available on site, including the height of the ribs and their spacing, and other technical information.

Information required for laying the reinforcement, casting the slab and its use thereafter

A reinforcement layout drawing should be prepared for each bay of each floor by the Structural Designer. The location, length, minimum overlap and minimum concrete cover of all reinforcement should be indicated. The grade of all reinforcement should also be noted. This grade can be checked against the identification tag for each reinforcement bundle delivered to site. Appropriate information about fibres should be given, if they are to be used.

Important reinforcement details (such as at construction joints, support locations, openings and edges) should be referenced and placed on this drawing.

The floor slab general arrangement drawings (or the Specification) should include the concrete performance requirements or mix details (including any details for fibre reinforcement), surface finish requirements, level tolerances and any restrictions on the location of construction joints. They should also identify the minimum concrete strength at which temporary supports may be removed, the minimum concrete strength at which temporary construction loads may be applied, and, where appropriate, the maximum allowable vehicular axle weight (for punching shear). Minimum concrete strengths may be given in terms of days after concreting.

Propping Information

As mentioned in Section 2.2, the Structural Designer should supply the Main Contractor with the floor dead load value to allow a propping solution to be developed.

4 DESIGN OF DECKING AND SLABS

This Section provides information about design principles and procedures, codified design rules, and guidance on good practice in design and detailing. Along with Section 5, it is aimed primarily at the Structural Designer, and any Delegated Designers. Summary boxes are used to highlight particular issues of good practice, or areas where particular attention is needed

4.1 Steel decking

The steel decking has two main structural functions:

- During concreting, the decking supports the weight of the wet concrete and reinforcement, together with the temporary loads associated with the construction process. It is normally intended to be used without temporary propping.
- In service, the decking acts ‘compositely’ with the concrete to support the loads on the floor. Composite action is obtained by shear bond and mechanical interlock between the concrete and the decking. This is achieved by the embossments rolled into the decking – similar to the deformations formed in rebar used in a reinforced concrete slab - and by any re-entrant parts in the deck profile (which prevent separation of the deck and the concrete).

The decking may also be used to stabilise the beams against lateral torsional buckling during construction, and to stabilise the building as a whole by acting as a diaphragm to transfer wind loads to the walls and columns (where it is designed to do so, and in particular where there are adequate fixings^[7]). The decking, together with either welded fabric reinforcement placed in the top of the slab or steel/synthetic fibres throughout the slab (see Section 6.2.1), also helps to control cracking of the concrete caused by shrinkage effects.

A.1.1 Decking profiles

Decking profiles are produced by a number of manufacturers in the UK. Although there are similarities between their profiles, the exact shape and dimensions depend on the particular manufacturer. There are two generic types of shallow decking; re-entrant (dovetail) profiles and trapezoidal profiles. Examples of re-entrant profiles are shown in Figure 4.1. Examples of trapezoidal profiles with a shoulder height of up to 60 mm (excluding the crest stiffener) are shown in Figure 4.2, and similar profiles deeper than this are shown in Figure 4.3.

The traditional shallow decking profiles are between 45 to 60 mm high, with a rib spacing usually of 150 to 333 mm. This type of decking typically spans 3 m, leading to frame grids of 9 m × 9 m or similar dimensions, using secondary beams at 3 m spacing, for which temporary propping is usually not required. Profiles up to 95 mm high overall have been developed which can achieve over 4.5 m spans without propping. Normally, the decking is laid continuously over a number of spans, which makes it stronger and stiffer than over a single span. More recently, a 160 mm (overall) profile has been developed which can span 6 m unpropped as a simply supported member.

Deep decking profiles, which are over 200 mm deep, are also available. These are mainly used in slim floor construction, which is considered separately in Section 7 of this guide.

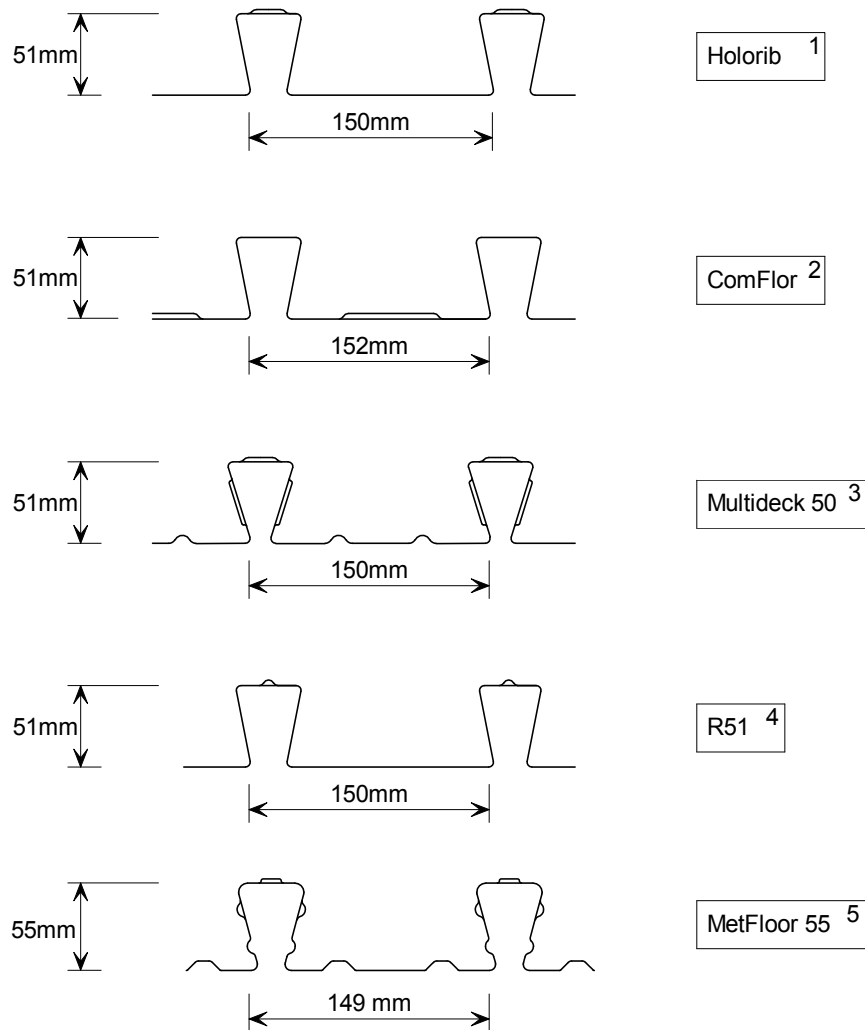

Figure 4.1 *Examples of re-entrant deck profiles used for composite slabs, supplied by:*

1. *Richard Lees Steel Decking Ltd.*
2. *Corus Panels and Profiles*
3. *Kingspan Structural Products Ltd.*
4. *Structural Metal Decks Ltd.*
5. *CMF Ltd.*

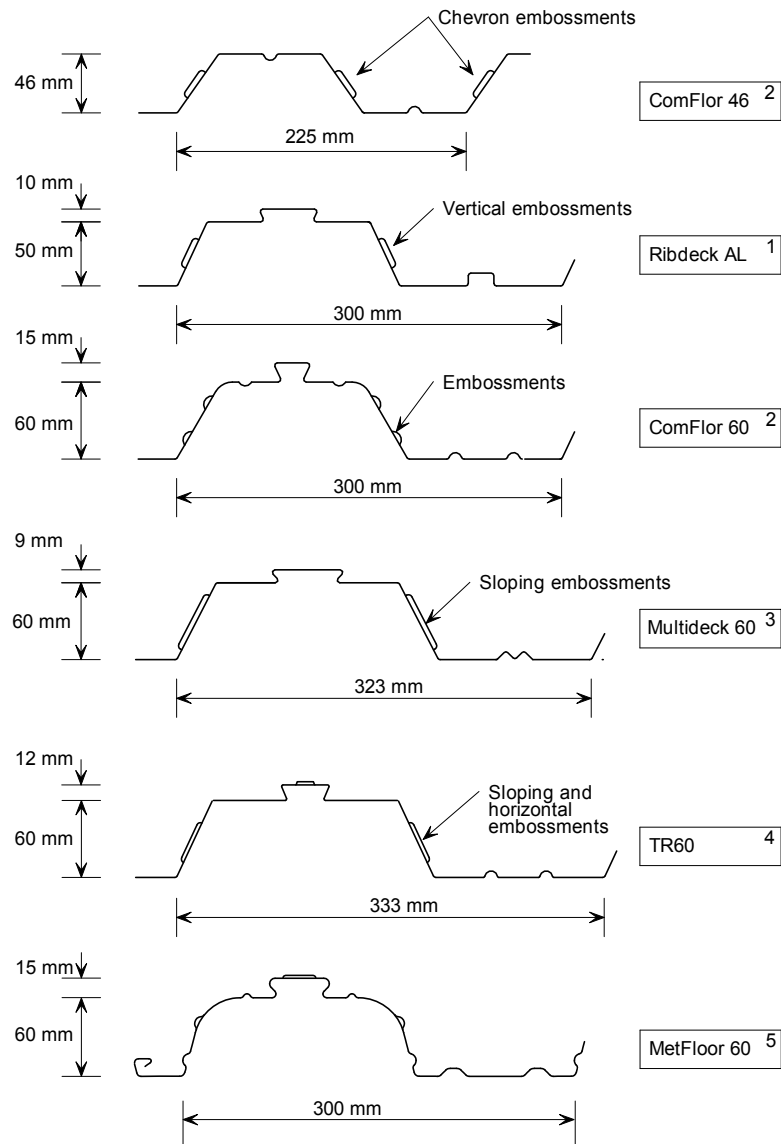

Figure 4.2 *Examples of trapezoidal deck profiles up to 60 mm deep (excluding the top stiffener) used for composite slabs, supplied by:*

1. *Richard Lees Steel Decking Ltd.*
2. *Corus Panels and Profiles*
3. *Kingspan Structural Products Ltd.*
4. *Structural Metal Decks Ltd.*
5. *CMF Ltd.*

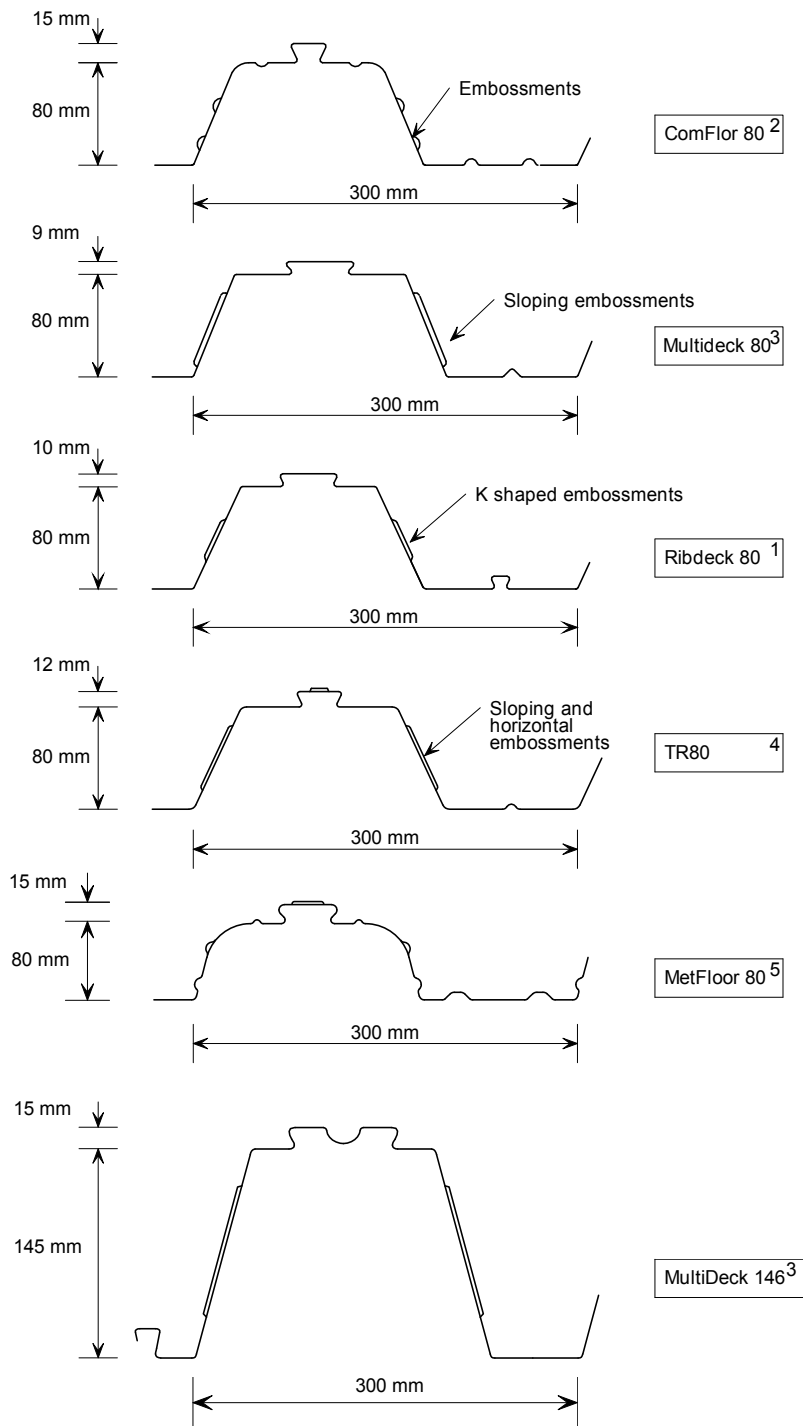

Figure 4.3 *Examples of trapezoidal deck profiles greater than 60 mm deep (excluding the top stiffener) used for composite slabs, supplied by:*

1. *Richard Lees Steel Decking Ltd.*
2. *Corus Panels and Profiles*
3. *Kingspan Structural Products Ltd.*
4. *Structural Metal Decks Ltd.*
5. *CMF Ltd.*

The grades of steel used for decking are specified in BS EN 10326^[81]. The common grade in the UK is S350 (the designation identifies the yield strength of the steel in N/mm²).

Decking is generally rolled from 0.9 to 1.2 mm thick strip steel. The spanning capability of a given decking profile clearly increases as the steel thickness increases, but not in direct proportion to the strength. The steel is galvanized before forming, and this is designated in the steel grade by the letters GD, followed by a number corresponding to the number of grammes of zinc per m². The normal specification is GD 275, i.e. 275 grammes of zinc per m², which results in a thickness of approximately 0.02 mm per face (sufficient to achieve an excellent design life in internal applications with mild exposure conditions). Thicker galvanized coatings of 350 g/m², and up to 600 g/m², are available for special applications where improved durability is needed, but specifications other than 275 g/m² will be difficult to obtain and are likely to require a large minimum order. ‘Thru-deck’ welding may also be affected. For this reason, polyester paints are sometimes applied over the galvanizing to provide a longer service life. Advice should be sought from the supplier/manufacturer when decking is to be used in a moderate or severe environment. Further advice on the use of composite construction in an aggressive environment is given in AD 247^[9].

Standard thickness galvanizing (275 g/m²) will give an excellent design life in most internal applications. Non-standard thicknesses of galvanizing are difficult to obtain and should not therefore be considered as a practical way of increasing durability.

4.1.2 Design for resistance

The temporary construction load usually governs the choice of decking profile.

When designing to Eurocodes, the construction loading that should be considered in the design of the decking is defined in BS EN 1991-1-6^[10] and its National Annex. Unfortunately, the provisions are a little unclear; the following is understood to be the recommended construction loading, which should be treated as a variable load:

- (i) 0.75 kN/m² generally
- (ii) 10% slab self weight or 0.75 kN/m², whichever is greater, over a 3 m × 3 m ‘working area’. This area should be treated as a moveable patch load that should be applied to cause maximum effect

This is shown diagrammatically in Figure 4.4.

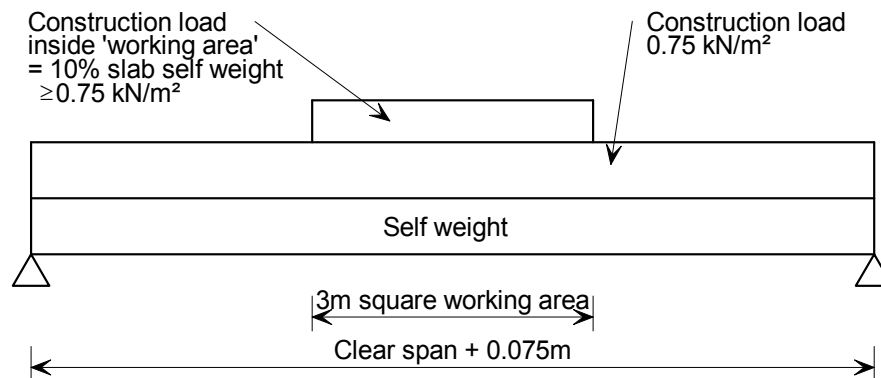

Figure 4.4 Loading on decking at the construction stage to BS EN 1991-1-6

When designing to BS 5950-4^[11], the construction loading is defined as:

- A uniformly distributed load of 1.5 kN/m² acting over one span. For spans less than 3 m, the load should be increased to $4.5/L_p$, where L_p is the effective span of the decking.
- A reduced load of 0.5 kN/m² on adjacent spans.

In both these cases, the construction loads are in addition to the self weight of the slab (usually 2 to 3 kN/m²), which may need to include an allowance for ‘ponding’ of the concrete (see Section 4.1.3). When concrete is poured using the ‘flood’ technique, care must be taken that the assumptions made in respect of the concrete thickness are reflected in the calculation of deflections of the slab and the supporting beams. The above load values allow for construction operatives, impact, the heaping of concrete during placing, hand tools, and small items of equipment and materials for immediate use. The loads are not intended to cover excessive impact or excessive heaping of concrete, pipeline or pumping loads.

In the Eurocodes, densities of the wet weight of reinforced concrete are given in BS EN 1991-1-1^[12], and the data is classified as ‘informative’. The data is for heavily reinforced construction associated with conventional reinforced concrete structures. The UK NA states that those values may be used, but it is recommended that the density of dry concrete used in composite floor construction should be 24 kN/m³ for normal weight concrete and 19 kN/m³ for lightweight concrete, increased to 25 kN/m³ and 20 kN/m³ respectively for wet concrete. The weight of the reinforcement should be added separately. The self weight of the wet concrete is treated as a variable load for the construction condition, but the reinforcement may be considered as a permanent load.

In BS 5950-4, wet densities are given as 2400 kg/m³ and 1900 kg/m³ for normal and lightweight concrete respectively, and similarly 2350 kg/m³ and 1800 kg/m³ for dry concrete. The self weight of the wet concrete is treated as a dead load.

The design of shallow decking is covered in BS EN 1991-1-3^[13]. The moment resistance of the section is established using an effective width model to take account of the thin steel elements in compression. Stiffeners (in the form of folds) are often introduced into the decking profile to increase the effectiveness of the section. The effective width approach is relatively conservative because the section behaviour is very complicated owing to local buckling, and so the section properties can be predicted neither easily nor accurately. The design of the decking is also covered in BS 5950-4 and BS 5950-6^[11], where a similar approach is given.

As an alternative to analytical procedures, the Standards also allow the use of testing in order to determine the performance of the decking. Spans 10% to 15% in excess of the limits predicted by simple elastic analysis using effective section models are possible. For this reason, manufacturers often provide load-span tables based on tests rather than on an elastic analysis approach.

In addition to tests under simulated uniform loading, further tests are normally carried out to check the resistance of the decking to localised loading. This provides information on the resistance to local loading from above as well as on the maximum allowable prop and support forces.

Decking design based on testing is more economical than design based on analytical models. Manufacturer's (empirical) information should therefore be used whenever possible.

Empirical information must not be used for designs outside the scope of the tests on which it is based. Load-span tables will generally only cover uniformly distributed loading.

4.1.3 Design for serviceability

It is necessary to limit the deflections at the construction stage to limit the volume of concrete that is placed on the decking; excess deflections will lead to 'ponding' of the concrete, and this will increase the dead loads on the structure. Deflection limits for the decking are given in BS EN 1994-1-1^[14], and in BS 5950-4. According to BS EN 1994-1-1, if the central deflection of the sheeting δ is greater than 1/10 of the slab thickness, ponding should be allowed for. In this situation the nominal thickness of the concrete over the complete span may be assumed to be increased by 0.7δ .

For the serviceability limit state, the recommended value of the deflection $\delta_{s,max}$ of steel sheeting under its own weight plus the weight of wet concrete is $L/180$ in BS EN 1994-1-1 (where L is the effective span between supports). In BS 5950-4, the limit on the residual deflection of the soffit of the deck (after concreting) is also given as span/180 (but not more than 20 mm), which may be increased to span/130 (but not more than 30 mm) if the effects of 'ponding' are included explicitly in the design.

The standard limits may be increased 'where it can be shown that greater deflections will not impair the strength and efficiency of the slab', although this is rarely applied. As a further check, it is recommended that the increased weight of concrete due to ponding should be included in the design of the support structure if the predicted deflection, without including the effect of ponding, is greater than one tenth of the overall slab depth.

The requirement for verification of the profiled sheeting at SLS in BS EN 1994-1-1 is expressed simply in terms of deflection under the weight of wet concrete and there is no requirement to check that such deflection should be elastic. However, it is recommended that there is also a check to ensure that there is no premature local buckling of the profile under the weight of wet concrete and the construction loading, to prevent irreversible deformation. This applies particularly to the intermediate support regions of continuous spans.

Excess deflections of the decking (and beams) may lead to 'ponding' of the concrete and therefore increased self weight of the slab. The decking and propping requirements should be chosen to minimise ponding.

4.1.4 Supports

Minimum bearing length

The bearing length is the longitudinal length of decking or slab in direct contact with the support. In each case, this length should be sufficient to satisfy the following relevant criterion. For decking, it should be sufficient to avoid excessive rib deformations, or web failure, near the supports during construction. For the slab, it should be sufficient to achieve the required load carrying capacity of the composite slab in service.

The recommended minimum bearing lengths shown in Figure 4.5 should be observed. The values given in this figure are based on the requirements of

BS EN 1994-1-1, but similar requirements are given in BS 5950-4. These limits should also be respected for temporary supports. The limits given represent nominal values that should be considered in the design and detailing, i.e. they include an allowance for construction deviations leading to slightly reduced values on site.

The recommended bearing lengths and support details differ depending upon the support material (steel, concrete, etc.), and they are different for interior and exterior (end) supports. Typical values and details are given in Figure 4.5 for the following:

- **Steel or concrete supports** - Composite slabs on steel or concrete supports should have minimum bearing lengths of 75 mm for the slab, and a minimum end bearing length of 50 mm for the decking (see Figure 4.5(a) and Figure 4.5(b)). For continuous decking, the minimum overall bearing length should be 75 mm.
- **Masonry and other support types** - Composite slabs on supports made of materials other than steel and concrete should have a minimum bearing length of 100 mm for the slab and a minimum end bearing length of 70 mm for the decking (see Figure 4.5(c) and Figure 4.5(d)). For continuous decking, the minimum overall bearing length should be 100 mm.

The flange width of supporting steel beams should be sized to supply the minimum bearing, by assuming that erection tolerances sum up unfavourably.

Details of how the decking should be fixed to supports are given in BCSA Publication No. 37/04^[6].

If ‘thru-deck’ welding of the studs is to be used to anchor the decking, so that it contributes to the transverse shear reinforcement (see Section 5.3.2), the dimensions specified in Figure 4.5 may need to be increased (see Figure 5.9).

In cases where the slab must transfer the wall loads from one storey to the next (rather than simply sitting on the top of a wall), the relatively lower volume of voids in a slab formed using a re-entrant profile means it may be better able to satisfy the design requirements.

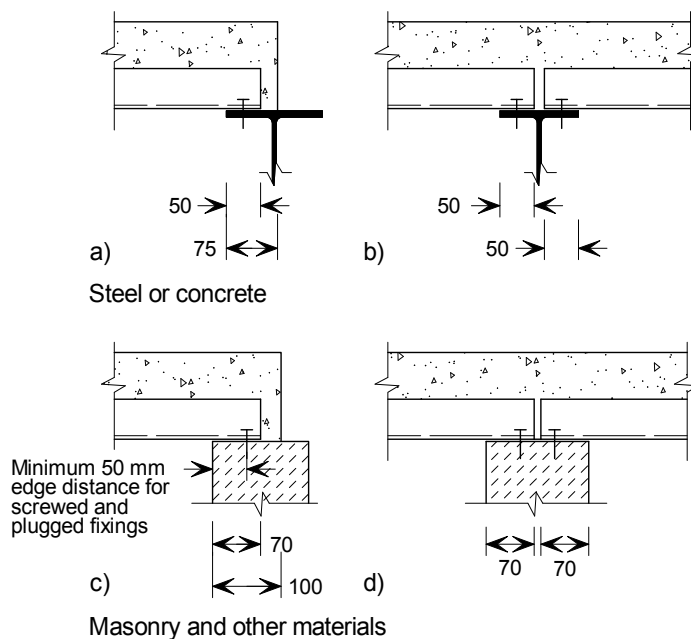

Figure 4.5 Minimum bearing lengths for permanent supports

Recommended support details

In addition to the 'standard' detail of a slab bearing on a steel beam or wall, there are a number of other commonly occurring support conditions which need to be considered at the design stage in order to avoid problems or delays on site. Some typical details are shown in Figure 4.6.

There are two basic cases at the interface of the decking with beams; where end support is required (Figure 4.6(a)), and where side support is required (Figure 4.6(b)). In both cases a steel 'shelf angle' is normally detailed as the decking support, and it is preferable to fix this during fabrication. Angle flashing is not suitable. To enable fixing of the decking, particularly in the case of an end support, it is important that the leg of the angle extends at least 50 mm beyond the flange of the beam. The support angles should be continuous and extend as close as is practical to beam connections, to minimise the unsupported length of the decking.

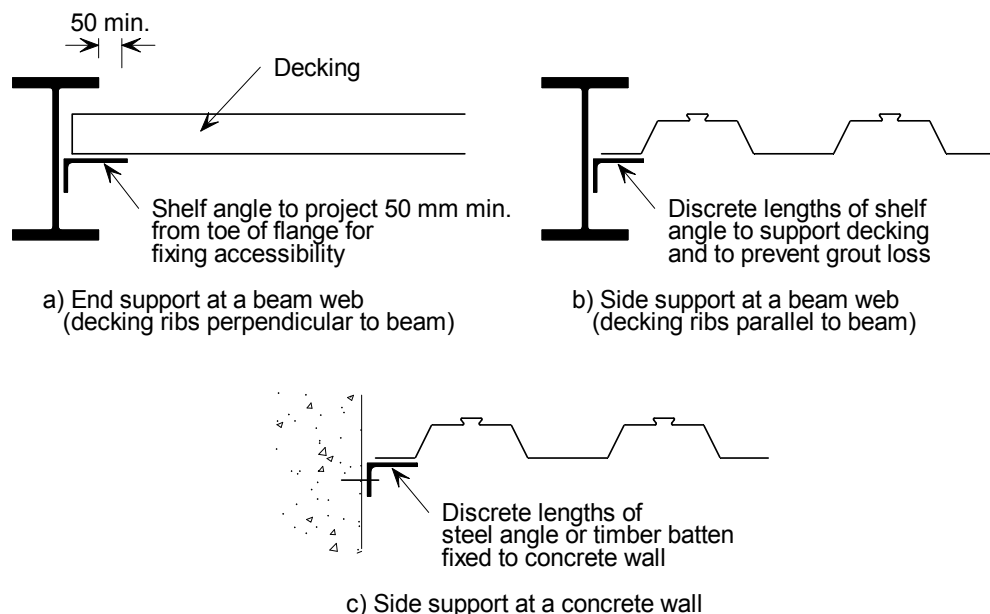

Figure 4.6 Decking support details at a beam web and at a concrete wall

Support is also required when the decking interfaces with a concrete wall. This may be provided by attaching a steel angle, flashing, or timber batten to the wall, preferably by using cast-in fixings (Figure 4.6(c)). Provision may need to be made to achieve reinforcement continuity between the wall and slab.

The decking should not cantilever beyond a support more than 600 mm (or $\frac{1}{4}$ of the span, if less) when spanning perpendicular to it. When the decking is spanning in a parallel direction, no cantilever is possible without extra support being provided – although the edge trim may cantilever a short distance (see Section 4.2.6)

The decking may also need to be supported around penetrations which reduce, or prevent, the effective bearing. Supports should be provided as part of the permanent steelwork, for example in the form of cleats or angles. Examples of when such supports are necessary include when the decking is penetrated by columns greater than 250 mm wide (without incoming beams on both axes), or by columns supported off beams. Figure 4.7 shows a recommended detail using a shelf angle to support the decking around a column.

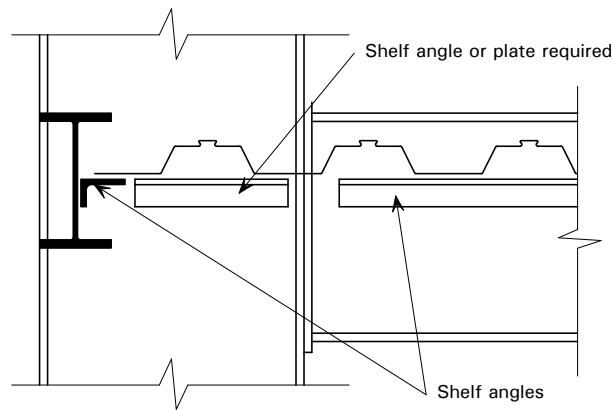

Figure 4.7 Decking support details at a column web

A less common detail is one in which the column is supported by a beam, in which case special detailing may be required to achieve sufficient bearing for the decking around the perimeter of the column. Where the deck is spanning in a direction perpendicular to the beam, the minimum bearing of 50 mm required to support the end of the decking may not be available because of the presence of the column base plate. Therefore, the beam flange may need to be extended by welding plates to the sides at the column position, as shown in Figure 4.8(a). If the column position does not coincide with a butt joint in the decking, the continuous decking sheet may have to be cut to fit around it. At this position, the decking should then be treated as if it was simply supported, and props maybe required locally. A similar situation may arise when flange splice plates are fixed to the top of the steel section, as shown in Figure 4.8(b).

Supports may also be needed if the decking is to be penetrated by temporary works structures (depending on the size of the penetration). To avoid problems in such situations, it is vital that there is good communication between the Main Contractor, who is responsible for the temporary works, and the Structural Designer, who should specify the appropriate steelwork.

The decking should be cut to fit around any penetration. A typical detail, with a column, is shown in Figure 4.9.

If temporary propping is proposed as a support around a penetration, this will clearly only be present during the construction stage, i.e. to support the decking. The completed slab may then need to include additional reinforcement, as might be necessary around any untrimmed opening in a reinforced concrete slab (see Section 4.2.6), in order to support the in-service loads. This reinforcement should be specified by the Structural Designer.

Sheet lengths

The tolerance in the sheet lengths for shallow decking is normally specified as +0 mm and -3 mm. A zero positive tolerance is used to avoid accumulations in length when sheets are butted in a long run. Long sheets could lead to the butt joint positions becoming increasingly displaced thus giving inadequate bearing for the sheets near the end of a run. Cutting on site might be needed to overcome this problem. It is, therefore, easier for the decking to be installed when sheets are slightly short. A small gap between sheets above the supporting beams is of no structural significance.

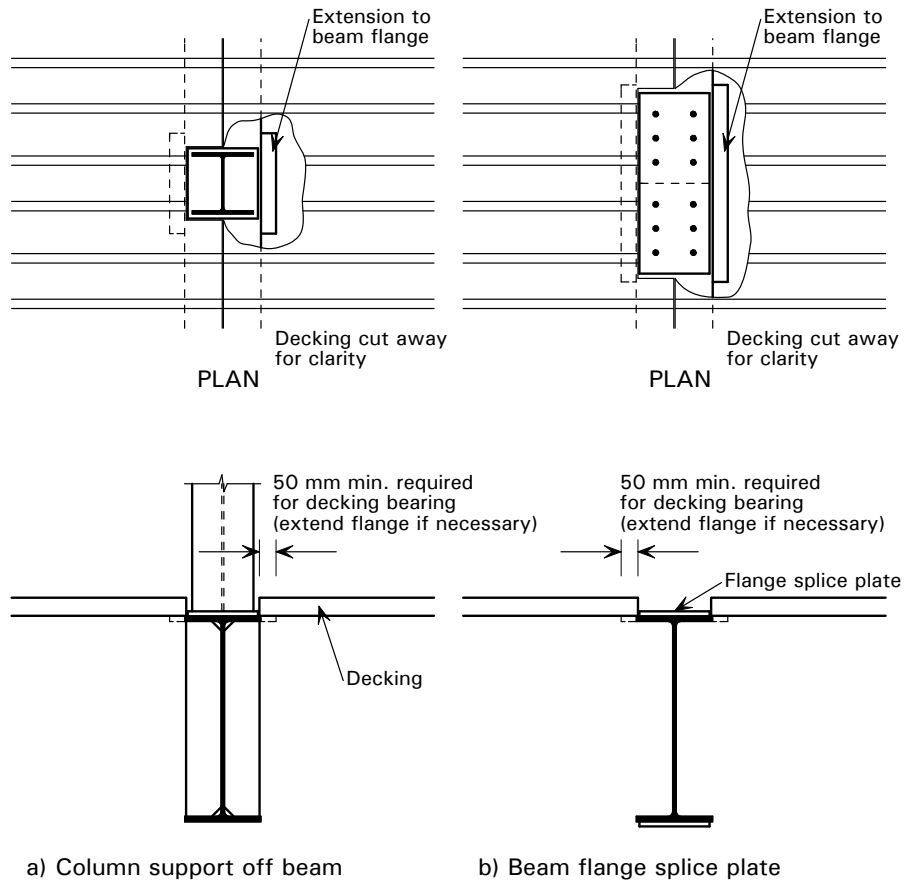

Figure 4.8 Decking details where a column is supported off a beam and where a beam flange plate occurs



Figure 4.9 Typical detail of decking installation around a column

4.2 Composite slabs

Composite slabs are normally used to span between 3 m and 4.5 m onto supporting beams or walls. The ability of the decking to support the construction loads, without the need for temporary propping, generally dictates such spans (longer spans are possible when props are used). Slab thicknesses are normally in the range 100 mm to 250 mm for shallow decking, and in the range 280 mm to 320 mm for deep decking.

When the concrete has gained sufficient strength, it acts in combination with the tensile strength of the decking to form a 'composite' slab. It can be considered as a reinforced concrete slab, using the decking as external reinforcement.

The load carrying capacity of composite slabs is normally dictated by the shear bond, enhanced by interlock, between the decking and the concrete, rather than by yielding of the decking. From tests, it is known that this shear bond generally breaks down when a 'slip' (relative displacement between the decking and the concrete) of 2 to 3 mm has occurred at the ends of the span. In practice, this will not occur below ultimate load levels. An initial slip, which is associated with the breakdown of the chemical bond, may occur at a lower level of load. The interlock resistance is therefore due to the performance of the embossments in the deck (which cause the concrete to 'ride-over' the decking), and the presence of re-entrant parts in the deck profile (which prevent the separation of the deck and the concrete).

Information on improving the bending resistance of composite slabs by providing additional reinforcement, or end anchorage in the form of shear connectors, can be found in BS EN 1994-1-1^[14] and BS 5950-4^[11].

If the slab is unpropped during construction, the decking alone resists the self-weight of the wet concrete and construction loads. Subsequent loads are applied to the composite section. If the slab is propped, all of the loads have to be resisted by the composite section. Surprisingly, this can lead to a reduction in the imposed load that the slab can support, because the applied horizontal shear at the decking-concrete interface increases. However, for both unpropped and propped conditions, load resistances well in excess of loading requirements for most buildings can be achieved.

Composite slabs are usually designed as simply supported members in the normal condition, with no account taken of the continuity offered by any reinforcement at the supports. Two methods of design are generally recognised, both of which use empirically derived information on the 'shear bond' resistance of the slab from uniformly distributed loading arrangements. The more traditional method, and one which is given in both BS EN 1994-1-1 and BS 5950-4, is the so-called '*m* and *k*' method (see Section 4.2.3). However, this method has limitations and is not particularly suitable for the analysis of concentrated line and point load conditions. An alternative method of design is included in the Eurocode, which is based on the principles of partial shear connection. This method provides a more logical approach to determine the slab's resistance to applied concentrated line or point loadings. It is not normally necessary for designers to understand the design methodology in detail, as manufacturers normally present the design data in the form of load-span tables, but these are only applicable for uniformly loaded conditions.

4.2.1 Concrete

Concrete types

Both normal weight concrete and lightweight concrete are used in composite slabs, but in the Eurocodes these are now referred to as normal concrete and lightweight aggregate concrete respectively. Normal concrete is made using dense aggregates from natural sources^[15]. Lightweight aggregate concrete contains artificially produced aggregates such as expanded pulverised fuel ash pellets. The cement and water contents are higher in lightweight concrete because of the absorption of water by the aggregate. For normal weight concrete, strength classes C25/30, C28/35 or C32/40 are normally chosen; for lightweight concrete, strength classes LC25/28, LC28/31 or LC32/35 are typical.

Lightweight concrete is commonly used because the obvious advantage of (typically) 25% weight saving can provide economic benefit for the overall design of the structure and its foundations (see Section 4.1.2 for concrete densities used for design). Lightweight concrete also has better fire insulating qualities than normal weight concrete, and so thinner slabs may be possible when the 'fire condition' governs the slab design (see Section 4.2.5). Unfortunately, lightweight concrete is not always readily obtainable in all areas of the UK. Also, it may not be appropriate if it is to be used in trafficked areas; to achieve a good wearing surface, the finishing process must cover the particles of lightweight coarse aggregate with an adequate, well-trowelled dense surface mortar layer. It also has poorer sound insulation properties than normal weight concrete.

Lightweight concrete offers several performance advantages, but it is not available in all parts of the UK.

Concrete grade

The Structural Designer chooses a concrete specification that is suitable for the intended application. This specification is normally chosen on the basis of the:

- overall structural requirements
- flooring finish, if any, to be laid on the slab
- exposure conditions.

The concrete strength class designations according to BS EN 206-1^[16] and BS 8500^[17] relate to the characteristic strength (95% probability of being exceeded) achieved after 28 days, based on cylinder or cube tests. The cylinder strength is about 80% of the strength of a 150 mm cube. Design standards provide rules that relate the design strength to the concrete grade.

As a minimum standard, concrete of strength class C25/30 or LC25/28 should be specified. In the case of concrete used as a wearing surface, the minimum strength class should be C28/35 (although C32/40 is preferred).

Surface finishes

There are two basic performance conditions; concrete to be used as a wearing surface, and concrete that is to be covered by raised floors, screeds, carpets, tiles, sheet vinyl, etc. When the concrete is to be used as a wearing surface, the concrete is first power floated. The specification should then require the slab to be allowed to stiffen for a short time prior to power trowelling, which

compresses and polishes the surface material, resulting in a harder and more durable surface. Recommendations for power floating and power trowelling are given in BS 8204^[18] and Concrete Society Technical Report No.34^[19].

When the concrete is not to be used as the wearing surface, it is recommended that a wood floated, skip floated or power floated finish is specified.

Drying

Because the concrete is only exposed on one surface of a composite floor, it can take a longer period than a traditional reinforced concrete slab to dry out. If moisture sensitive floorings and/or adhesives are to be applied, many months may be needed before the slab is sufficiently dry to accept them. Measures such as the specification of special concrete, dewatering or surface vapour-proof membranes, may need to be considered if inadequate time for drying is allowed in the contract programme.

If surface vapour-proof membranes are used, moisture will be trapped in the slab. This trapped moisture will not be detrimental to the concrete or the decking, as the steel in contact with the concrete is prevented from corrosion by its high pH. The provision of small holes, perforations, in the decking to aid drying is ineffective; the area represented by the holes is insufficient to have any significant effect on drying times.

AD 163^[20] provides additional guidance on provisions for water vapour release.

Level and flatness

It is recommended that a precisely level and flat concrete floor is not specified unless it is absolutely necessary, as it is difficult to achieve because the tamping rails are usually positioned along the support beams, which deflect under the self weight of the finished floor. To achieve greater accuracy, it is necessary to estimate the central deflection of the beams and to set the tamping rails along each beam to allow for this deflection. This can result in errors because, in practice, the beams may not deflect as much as expected (e.g. because of the stiffness of the beam-column connections). It is reasonable to set the rails on the basis that the beams will deflect 30% less than predicted by simple theory.

In propped construction, further deflection occurs on removal of the props. Subsequent deflections will be greater the earlier the props are removed (due to the lower stiffness of the 'immature' concrete). Therefore, props should not be removed until the concrete has gained its design strength.

As deviations in level are dependent on the deflection of the composite slab and the supporting beams, tolerances within which these deviations must lie should only be specified at points where there is negligible deflection of the supporting structure, i.e. at columns. The Main Contractor will be able to do little to correct matters if deviations exceed tolerances specified at other points.

The following tolerances are recommended:

Top surface of concrete, level to datum	± 15 mm
Top surface of supporting steel beams, level to datum	± 10 mm

For the reasons discussed above, a thickness tolerance should only be specified at the column locations. If it is really necessary to specify absolute levels for the top surface, the thickness tolerance should be calculated by combining the top

and bottom level tolerances using a method given in BS 5606²¹. This results in a slab thickness tolerance of ± 18 mm. To achieve slightly tighter tolerances on thickness, the level of the concrete should be specified relative to the level of the supporting steelwork.

Owing to the accumulative deflections of the deck and beams, it is not practical to specify tight flatness tolerances on composite slabs. BS 8204^[18] gives three tolerances for floor flatness, as shown in Table 4.1. The deviation is determined by measuring the maximum gap beneath a 3 m straight edge laid on the surface. For composite slabs, the straight edge must always be positioned parallel to the supporting beams, i.e. perpendicular to the decking span.

Table 4.1 *Surface flatness tolerances*

BS 8204 Flatness Designation	Maximum gap (mm) below a 2 m straight edge laid on the surface	Comments
SR1	3 (1 in 667)	Not achievable on suspended floors of any construction.
SR2	5 (1 in 400)	May be achievable on parts of a composite floor, but will not be achievable over all of a floor, owing to deflections. This is a tight flatness tolerance and high levels of workmanship are required to achieve SR2 on any type of suspended floor.
SR3	10 (1 in 200)	May be achievable over most of a floor, depending on the deflections of the supporting beams.

4.2.2 Reinforcement

Bar reinforcement

Types and details

The bar reinforcement in composite slabs usually takes the form of a relatively light welded fabric, commonly supplemented by some bar reinforcement. The fabric reinforcement is required to perform a number of functions:

- Provide bending resistance at the supports of the slab in the fire condition (this reinforcement is usually ignored under ‘normal’ load conditions).
- Reduce and control cracking at the supports, which occurs because of flexural tension and differential shrinkage effects.
- Distribute the effects of localised point loads and line loads.
- Strengthen the edges of openings (see Section 4.2.6).
- Act as transverse reinforcement for the composite beams (see Section 5.3.2).

The most common fabric sizes are A142 and A193 (using designations according to BS 4483^[22]), with the numbers indicating the cross-sectional area (mm²) of reinforcing bars per metre width. The fabric is normally manufactured in ‘sheets’ that are 2.4 m wide and 4.8 m long. ‘A’ type fabric has layers of bars equally spaced in both directions (known as ‘square’ fabric) and is most commonly used. It is possible to order special fabric with heavier wires or closer spacing in one direction, such as ‘B’ or ‘C’ type fabrics. ‘B’ type ‘structural’ fabrics have longitudinal bars at 100 mm centres and transverse bars at 200 mm centres. These can be used when highly reinforced areas are

required for structural or fire resistance purposes. 'C' type 'highway' fabrics are intended for highway use and have only very light reinforcement in the transverse direction. C type fabrics should not be used in composite floors.

Fabric sizes less than A142 are not recommended because of their poor performance as fire reinforcement and inability to control shrinkage, and are considered as non-structural.

Bar reinforcement may be used to supplement the fabric:

- To achieve longer fire resistance periods.
- To reinforce the slab around significant openings.
- When additional transverse reinforcement is needed.
- To achieve greater crack control.

Reinforcement should comply with BS 4483^[22] (fabric) or BS 4449^[23] (bars), and the detailing of it should be in accordance with BS EN 1992-1-1^[24] or BS 8110^[30] and BS 8666^[25]. Bar reinforcement is produced in three ductility grades; A, B or C. In the UK, bar reinforcement of ductility grade B is normally used, but most fabric is supplied with ductility grade A. The ductility grade of the reinforcement has no effect on the lap and anchorage lengths. The bars in fabric supplied to BS 4483 are ribbed, and this will reduce the required anchorage lengths compared to plain bars. BS EN 1992-1-1 assumes that bars are ribbed, but BS 8110 allows for the use of ribbed and plain bars.

In shallow composite slabs, the reinforcement should be supported sufficiently high above the top of the decking to allow concrete placement around the bars. The required top cover depends on the concrete class and the exposure. Recommendations are given in Tables NA.2 and NA.3 to BS EN 1992-1-1; these present the same information as in BS 8500-1^[17] but in a more compact form. The Structural Designer should determine the relevant exposure condition for the top of the floor. The following exposure conditions apply:

- For a floor in a dry protected environment, e.g. in enveloped buildings such as offices, the exposure class for the concrete is XC1.
- For an external floor exposed to high levels of humidity, the exposure class for the concrete would be XC3 or XC4.
- For a floor exposed in a marine environment, the exposure class would be XS1, XS2 or XS3.
- For a floor that is exposed to freeze-thaw cycles, the exposure class would be XS (see BS 8500-1 for recommendations for this class).

Table NA.2 in BS EN 1992-1-1 applies where the intended working life is 50 years and Table NA.3 applies where the intended working life is 100 years (not normally applicable to buildings).

In car parks, where the slab is exposed to chlorides and freeze/thaw attack, the exposure class is XD3 or, if the intended design life does not exceed 30 years, the exposure class is XF3 or XF4, provided that the concrete surface is protected by an effective, durable and long-lasting waterproof membrane. (Any membrane should be a waterproof coating that prevents the ingress of water containing dissolved de-icing salts into the concrete, including at any joints and cracks in the concrete.)

Recommended covers for XC1 and XC3/4 exposure classes are given in Table 4.2. Refer to BS 8500-1 for covers and concrete specifications for other exposure classes.

The recommendations for durability in this section only relate to the concrete and reinforcement. The corrosion protection of the metal decking is covered in Section A.1.1

Table 4.2 *Minimum reinforcement covers for various levels of exposure*

Aggregate Type	Normal weight					Lightweight		
	C25/30	C28/35	C32/40	C35/45	C40/50	LC25/28	LC28/31	LC32/35
Concrete Strength Class								
Max Water cement ratio	0.65	0.60	0.55	0.50	0.45	0.65	0.60	0.55
Min cement content for 20 mm aggregate (kg/m³)	260	280	300	320	340	260	280	300
Min cement content for 14 mm aggregate (kg/m³)	280	300	320	340	360	280	300	320
Min cement content for 10 mm aggregate (kg/m³)	300	320	340	360	360	300	320	360
Nominal cover in mm to reinforcement according to the exposure level:								
XC1	25	25	25	25	25	25	25	25
XC3/4	45	40	35	35	30	45	40	35

Notes:

- (a) These values are taken from BS 8500-1^[17] and BS EN 206-1^[16]
- (b) The exposure conditions are defined in BS 8500-1. For internal floors in a watertight heated building, with dry conditions the exposure condition would be XC1. For floors subject to high humidity or cyclical wet and dry conditions the exposure condition would be XC3/4. More severe exposure conditions may be applicable in some conditions, e.g. car parks.
- (c) Nominal Cover: BS 8500-1 lists minimum covers not nominal covers. The nominal covers listed in Table 4.2 are the minimum covers given in BS 8500-1 plus a fixing tolerance (Δc) of 10 mm. The covers listed are for an intended working life of 50 years. For an intended working life of 100 years no change is required to the XC1 exposure class covers, and 15 mm should be added to the XC3/4 covers.
- (d) In practice, nominal covers less than 30 mm with light fabrics are not recommended owing to practical difficulty in supporting the light fabric in the correct location.
- (e) The listed covers are for durability purposes. Greater covers may be needed for fire resistance considerations.

Recommended tension laps and anchorage lengths for welded fabric and bars for design to BS 8110 are given in Table 4.3, and for design to BS EN 1992-1-1 in Table 4.4.

Table 4.3 *Recommended tension laps and anchorage lengths for welded fabric and bars to BS 8110*

Aggregate Type		Normal			Lightweight		
		C25/28	C28/30	C28/31	LC28/35	LC32/35	LC32/40
Strength Class		C25/28	C28/30	C28/31	LC28/35	LC32/35	LC32/40
Reinforcement Type	Wire/Bar Type						
Grade 500 Bar of diameter d	Deformed Type 2	44d	40d	38d	56d	54d	50d
A142 Fabric (6 mm wires at 200 centres)	Deformed Type 2	275	250	250	350	325	300
A193 Fabric (7 mm wires at 200 mm centres)	Deformed Type 2	300	275	275	400	375	350
A252 Fabric (8 mm wires at 200 mm centres)	Deformed Type 2	350	325	300	450	425	400
A393 Fabric (10 mm wires at 200 mm centres)	Deformed Type 2	440	400	375	550	550	500

Notes:

- (a) Table 4.3 is based on information given in BS 8110-1^[30], assuming fully stressed bars/fabric. It should be noted however that the recommendations determined in accordance with BS EN 1992-1-1 (as shown in Table 4.4, below) may differ from the above.
- (b) Where a lap occurs at the top of a section and the minimum cover is less than twice the size of the lapped reinforcement, the lap length should be increased by a factor of 1.4.
- (c) Deformed Type 2 Bars/Wires: Bars with transverse ribs of substantially uniform spacing, which protrude beyond the main round part of the bars/wires. There may be longitudinal ribs. Note: The majority of deformed high yield reinforcement available in the UK is Type 2.
- (d) The minimum Lap/Anchorage length for bars and fabric should be 300 mm and 250 mm respectively.

Table 4.4 *Recommended tension laps and anchorage lengths for welded fabric and bars to BS EN 1992-1-1 in C25/30 concrete*

		Bond condition	Reinforcement in tension, bar diameter, ϕ (mm)							
			8	10	12	16	20	25	32	40
Anchorage length, l_{bd}	Straight bars only	Good	230	320	410	600	780	1010	1300	1760
		Poor	330	450	580	850	1120	1450	1850	2510
	Other bars	Good	320	410	490	650	810	1010	1300	1760
		Poor	460	580	700	930	1160	1450	1850	2510
Lap length, l_o	50% lapped in one location ($\alpha_6 = 1.4$)	Good	320	440	570	830	1090	1420	1810	2460
		Poor	460	630	820	1190	1560	2020	2590	3520
	100% lapped in one location ($\alpha_6 = 1.5$)	Good	340	470	610	890	1170	1520	1940	2640
		Poor	490	680	870	1270	1670	2170	2770	3770

Notes

- 1 Nominal cover to all sides and distance between bars ≥ 25 mm (i.e. $\alpha_2 < 1$).
- 2 It is assumed that the coefficients to allow for factors effecting the anchorage (defined in BS EN 1992-1-1, clause 8.4.4.) $\alpha_1 = \alpha_3 = \alpha_4 = \alpha_5 = 1.0$.
- 3 Design stress has been taken as 435 MPa. Where the design stress in the bar at the position from where the anchorage is measured, σ_{sd} , is less than 435 MPa the figures in this table can be factored by $\sigma_{sd}/435$. The minimum lap length is given in clause 8.7.3 of BS EN 1992-1-1.
- 4 The anchorage and lap lengths have been rounded up to the nearest 10 mm.
- 5 Where 33% of bars are lapped in one location, decrease the lap lengths for '50% lapped in one location' by a factor of 0.82.
- 6 The reinforcement ductility class has no effect on lap and anchorage lengths.
- 7 In slabs up to 250 mm thick all horizontal reinforcement can be considered to have Good Bond conditions.
- 8 In slabs over 250 mm thick horizontal reinforcement in the bottom 250 mm can be considered to have Good Bond conditions. Reinforcement in the top zone (above 250 mm from the bottom) can be considered to have Poor Bond conditions.
- 9 The information in this table is taken from *How to design concrete structures to Eurocode 2* [26]. This publication should be consulted for other concrete classes or for further guidance.

Concrete class	C20/25	C28/35	C30/37	C32/40	C35/45	C40/50	C45/55	C50/60
Factor	1.16	0.93	0.89	0.85	0.80	0.73	0.68	0.63

Fibre reinforcement

Fibre reinforcement consists of short fibres made from steel, polypropylene or a combination of both, which are mixed into the concrete prior to placement. Under controlled circumstances, fibres may be substituted for some or all of the fabric reinforcement. Use of fibre reinforcement results in a three dimensional reinforced concrete composite slab.

The performance of fibre reinforcement is verified empirically, specifically for fire resistance and for longitudinal shear transfer, using the same testing regimes that are used to validate the use of traditional reinforcement within steel deck composite floors.

Considerable benefits can be achieved using fibre reinforcement, including a reduction in labour costs and a saving on the construction programme. The requirement for longitudinal shear reinforcement, in the form of bars or fabric,

can be dramatically reduced and only a minimal amount of fabric reinforcement need be purchased, transported and stored. There is less usage of the crane as there are fewer lifting operations. The installation of the floor is easier and safer because there is less reinforcement to obstruct the floor working area and to handle, fix and check, and this can reduce installation times by up to 20%.

Independent testing has shown that fibre reinforcement systems can provide an equivalent or superior performance to traditional welded wire fabric solutions, although local reinforcement may be necessary in locations of concentrated loads. Fibre reinforcement provides resistance to plastic shrinkage, settlement cracking and toughness, but the performance is related to the specific fibre.

BS EN 14889^[27] covers the requirements for fibres used as concrete reinforcement. Part 1 covers steel fibres, and Part 2 polymer fibres. Care should be taken with the selection of polymer fibres, as only Class 11 (macro) fibres in accordance with BS EN 14889 are suitable as a replacement for traditional fabric reinforcement in steel deck composite slabs.

It is very important to note that fibre reinforced composite slabs are **not** a generic product. A specific type and dosage of fibres must be used according to the fibre manufacturer's specification for the particular deck, and other deck or fibre types cannot be substituted.

When using a fibre reinforcement solution, it is still general practice to use U-bars on composite edge beams, bar reinforcement around openings in the slab, and fabric or bar reinforcement at construction joints, or where the composite slab cantilevers beyond a support.

More information on fibre reinforcement is given in Section 6.2.1. Further guidance on the use of steel or macro-synthetic fibre-reinforced concrete can be found in Concrete Society Technical Reports No. 63^[40] and 65^[41] respectively.

Fiber reinforcement is provided within the concrete that is delivered and ready to pump on site. This can reduce installation times by up to 20%.

4.2.3 Design for resistance

The performance of a composite slab with a particular decking profile can only be assessed readily by testing. Test procedures are set out in both BS EN 1994-1-1^[14] and BS 5950-4^[11]. The tests must cover the complete range of the key design parameters (usually slab depth and span). The specimens are first subject to dynamic load (5,000 load cycles up to 1.5 times the working load are specified in BS EN 1994-1-1, but 10,000 cycles are required by BS 5950-4). Following this, a static load is applied and increased until failure occurs. The objective of the dynamic part of the test is to break any adhesion bond, so that only the more stable mechanical interlock remains.

The test procedure is such that all loads are applied to the composite section to simulate a uniformly loaded condition. The test results are then presented in terms of empirical constants, either (m and k) or Tau (τ), that can be used to quantify the interaction between the steel and concrete.

As far as slab design is concerned, the Structural Designer will not undertake tests to determine the m and k or Tau (τ) factors. These constants are used by the decking manufacturers themselves in order to present designers with a range of load-span tables for uniformly loaded conditions for their specific products.

Specific checks are necessary where there are concentrated line or point loads whose effect is normally greater than that of a nominal uniformly distributed blanket load.

The vertical shear resistance of a reinforced composite slab using bar or fabric is assessed as for a reinforced concrete slab, using guidance given in BS EN 1992-1-1^[24] or BS 5950-4. ‘Punching’ shear resistance, against localised loads, should also be assessed using these Standards. When fibre reinforcement is used, designers should seek guidance from the manufacturers.

Manufacturers’ load-span tables for slabs are normally based on testing (in order to minimise conservatism). Designers should take care to ensure that they do not use this information for situations that are not covered by the scope of the testing especially if concentrated line or point loads are applied to the slab.

4.2.4 Design for serviceability

Crack control

There is a risk of cracking in the concrete in all composite slabs due to the restraint to drying shrinkage provided by the steel decking and primary steelwork, even though the decking effectively acts as reinforcement and helps to distribute the shrinkage strains so that large cracks do not form. However, cracks do not normally pose a durability or serviceability hazard. Only where the surface of the slab is used as a wearing surface, or where terrazzo or other ‘rigid’ floor coverings are to be used, may specific reinforcement (in addition to the ‘standard’ fabric) be required in order to control the cracking. When cracking is an issue, reinforcement percentages in excess of 0.3% will normally be required in order to limit crack widths to the recommended limit. Fabric, rather than bars, is generally used to control cracking.

According to BS EN 1994-1-1, when continuous slabs are designed as simply-supported, the minimum cross-sectional area of the anti-crack reinforcement within the depth of the concrete cover to the decking should be as follows:

- 0.2% of the cross-sectional area of the concrete above the ribs for unpropped construction
- 0.4% of the cross-sectional area of the concrete above the ribs for propped construction.

It is possible that larger crack widths will occur over the intermediate supports with propped construction, because the full self-weight of the slab is applied in the composite slab on removal of the props, which explains the higher minimum percentage reinforcement required.

The above amounts do not automatically ensure that the crack widths are less than the typical value of 0.3 mm given in BS EN 1992-1-1 (and the UK National Annex to this code) for certain exposure classes. If the exposure class (or the floor finish) is such that cracking needs to be controlled, the slab should be designed as continuous, and the crack widths in hogging moment regions evaluated according to BS EN 1992-1-1.

Experience shows that the greatest risk of cracking is over supporting beams, owing to the combination of restrained drying shrinkage and flexural action^[28]. ‘Induced’ joints may be used to reduce the risk of random cracking at these

locations. Such joints can be formed by sawing the slab, but clearly, care is needed to prevent the reinforcement required for fire resistance and longitudinal shear resistance from being damaged or severed. However, where cracking has to be controlled, a more reliable measure is to use additional crack control reinforcement at the support.

When fibre reinforcement is to be used in place of bar/fabric reinforcement the suppliers of the fibres should be consulted regarding crack control measures.

Deflections

Deflections due to loading applied to the composite member should be calculated using elastic analysis, neglecting the effects of shrinkage. For an internal span of a continuous slab, where the shear connection is achieved by either mechanical or frictional interlock, or end anchorage by through-deck welded studs, the deflection may be determined using the average value of the cracked and uncracked second moment of area may be taken. This applies both for design to the Eurocodes and design to BS 5950, but the modular ratio for long-term and short-term effects is calculated slightly differently in BS EN 1994-1-1 and BS 5950-4 (which refers to BS 5950-3).

BS EN 1994-1-1 permits calculations of the deflection of the composite slab to be omitted if both the following conditions are satisfied for external or simply-supported spans:

- the span/depth ratio of the slab does not exceed certain limits specified in BS EN 1992-1-1 for lightly stressed concrete (shown here in Table 4.5); and
- the load causing an end slip of 0.5 mm in the (long span) tests on composite slabs exceeds 1.2 times the design service load.

Table 4.5 *General rules for the slab maximum span-to-depth ratios in accordance with BS EN 1992-1-1*

	Normal concrete	Lightweight concrete
Single spans	20	18.8
End spans	26	24.5
Internal spans	30	28.3

For cases where the end slip exceeds 0.5 mm at a load below 1.2 times the design service load, two options exist for the designer:

- (i) end anchors should be provided; or
- (ii) deflections should be calculated including the effect of end slip.

Should the behaviour of the shear connection between the sheet and the concrete not be known from tests on composite slabs with end anchorage, BS EN 1994-1-1 permits a tied-arch model to be used. Guidance for designers on this case can be found in the *Designer's guide to BS EN 1994-1-1* ^[29].

For design to BS 5950-4, there are also simple design rules to ensure adequate deflection behaviour of a composite slab. Calculation of deflections is not necessary when designing to this code if the span-to-depth ratios are not greater than those given in Table 4.7. Confirming that the slab satisfies these limits will ensure that excessive deflections are avoided. The effective span of the decking is defined in BS 5950-4 as the smaller of:

- the distance between the centres of the supports, and
- the clear span between the supports plus the effective depth of the composite slab.

The values in Table 4.7 apply to slabs under uniformly distributed loading, with nominal continuity reinforcement (0.1%) over the intermediate supports, i.e. they are designed as simply supported. For slabs with full continuity reinforcement over the supports, reference should be made to BS 8110^[30]. Deflections should be calculated explicitly for slabs that fail to satisfy the span-to-depth ratio or reinforcement limits. BS 5950-4 recommends that the deflection of the composite slab should not normally exceed the limits in Table 4.6.

Table 4.6 *Recommended limits for the maximum deflection of composite slabs given in BS 5950-4*

Criterion	Recommended Limit
Deflection due to the imposed load	$L_s/350$ or 20 mm, whichever is the lesser
Deflection due to the total load less the deflection due to the self-weight of the slab plus, when props are used, the deflection due to prop removal	$L/250$

The stiffness of slabs reinforced with conventional fabric reinforcement can be determined using ‘normal’ reinforced concrete design rules (assuming fully effective bond between the decking and the concrete). When fibre reinforced concrete is used, advice on the slab stiffness should be sought from the manufacturer.

Table 4.7 *General rules for the slab maximum span-to-depth ratios in accordance with BS 5950-4*

	Normal concrete	Lightweight concrete	Values apply to supported spans with nominal continuity reinforcement, subject to uniformly distributed loading
Single spans	30	25	
End spans	35	30	
Internal spans	38	33	

Dynamic sensitivity

The dynamic sensitivity of composite slabs is not normally critical, because they are relatively stiff compared with the beams, although the dynamics of the **whole floor** should be considered, as explained in Section 5.2.2.

Cracking of internal concrete surfaces will generally not compromise the structural performance of a building, so for economic design its consequences may often be ignored.

4.2.5 Design for fire resistance

The required fire performance of floor slabs is defined by the Approved Document B to the National Building Regulations. The Approved Document requires the slab performance to be assessed based on criteria for insulation 'I', integrity 'E' and load bearing capacity 'R'. For design to the Eurocodes, BS EN1994-1-2^[31] and the UK National Annex to BS EN1994-1-2^[32] provide guidance on how composite slabs may be designed to meet these criteria. For UK design, guidance is available in BS 5950-8^[11].

The insulation criterion is satisfied by providing adequate slab thickness to ensure that the temperature of the unexposed surface of the slab does not exceed 140°C. BS 5950-8 and the UK National Annex to EN1994-1-2 provide a table of recommended concrete thicknesses to satisfy the insulation criterion for common periods of fire resistance. The minimum thickness of concrete required to satisfy the insulation requirements is shown in Table 4.8 for trapezoidal decks and Table 4.9 for re-entrant decks. Figure 4.10 shows that the insulation depth depends on the type of profile, and it is the concrete cover to the main crest of the deck for trapezoidal profiles and the full slab depth for re-entrant profiles.

Table 4.8 *Minimum thickness of concrete, measured above the steel deck, for trapezoidal profiled steel deck exposed to the standard fire*

Concrete type	Minimum thickness of concrete (mm) for a fire resistance period (mins) of:					
	30	60	90	120	180	240
Normal concrete (All cases)	60	70	80	90	115	130
Lightweight concrete (All cases)	50	60	70	80	100	115

Table 4.9 *Minimum thickness of slab for re-entrant profiled steel sheets exposed to the standard fire*

Concrete type	Minimum thickness of concrete (mm) for a fire resistance period (min) of:					
	30	60	90	120	180	240
Normal concrete	90	90	110	125	150	170
Lightweight concrete	90	90	105	115	135	150

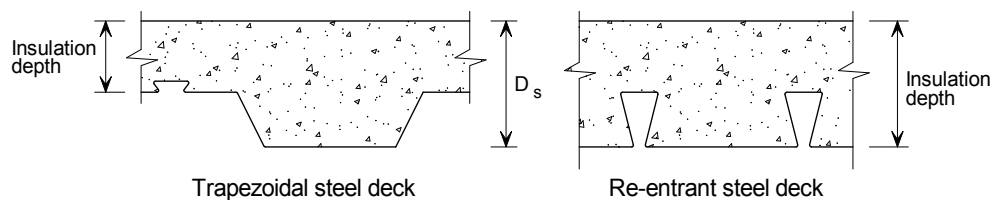

Figure 4.10 *Minimum insulation depth measurement*

EN1994-1-2 permits the designer to calculate the bending resistance and insulation properties assuming that composite slabs fulfil the integrity criterion.

Fire tests have been carried out on slabs with conventional fabric reinforcement, and on fibre reinforced slabs.

The load bearing resistance of the slab at elevated temperatures can be determined by calculation in accordance with the principles given in EN1994-1-2. The UK National Annex provides additional guidance on determining design temperatures for UK decking geometries.

Depending on the span required, an increased size of fabric may need to be used, or extra bars may need to be placed in the troughs of the deck, to satisfy the load bearing criteria (R) for the fire condition. In either case, the additional reinforcement is used to compensate for the loss of strength of the (exposed) decking at elevated temperatures. Design guidance covering this aspect is normally given by the decking manufacturers in their design tables. These design tables are based on the extended application of fire test results and provide product specific guidance which will result in the most economic solutions for fire design. The extended applications of the fire test results are based on a design model for plastic resistance that is in accordance with the principles of EN1994-1-2 §4.3.1 and the recommendations of the UK National Annex to EN1994-1-2.

In the UK National Annex, the use of Informative Annex D of EN1994-1-2 is rejected as many UK decking profiles are outside the limits of the field of application. It was found that when the methods in Annex D were applied to these decking geometries, unusable answers were obtained. For projects in other European countries where the use of Annex D is recommended, it is likely that the manufacturer's fire design tables will be the only valid method of design for UK decking profiles.

Slab designs that comply with the recommendations of EN1994-1-1 for room temperature design are deemed to have 30 minutes fire resistance, when assessed under the load bearing criteria 'R', but these slabs still need to be checked for compliance with the insulation criteria.

Further information on the calculation of load bearing resistance of composite slabs can be obtained from P375^[33].

4.2.6 Openings and edges

Openings

Openings can be accommodated readily in composite slabs. Some advice as to limits on the size of openings, and the provision of any extra reinforcement that may be required, is normally given in the notes accompanying a decking manufacturer's load-span tables. Further advice is given here on issues relating to design with shallow decking (deep decking is covered in Section 7), and advice relating to the construction of openings is given in the BCSA *Code of practice for metal decking and stud welding*^[6].

Openings may be categorised by their size:

- Small - openings up to 300 mm square - unlikely to present a problem structurally and do not normally require additional reinforcement.
- Medium - openings between 300 mm and 700 mm square - normally require additional reinforcement to be placed in the slab. This is also the case if the openings are placed close together.

- Large - openings greater than 700 mm square - should be trimmed with addition permanent steelwork back to the support beams.

It should be noted that slightly different dimensions from those given above may be quoted in a manufacturer's literature for specific profiles, in which case the manufacturer's guidance should be followed.

For small and medium size openings, normal practice is for the Main Contractor to form an opening by 'boxing-out' an area of decking using timber or polystyrene inserts before concreting, as shown in Figure 4.11. The decking should not be cut until the concrete has gained 75% of its design strength. Then it may be cut or burnt away to form the opening, and the cut edges bent up or ground off. If cutting the deck prior to casting is unavoidable, temporary propping is likely to be required. This may have implications on the slab design, and the Structural Designer should be consulted.

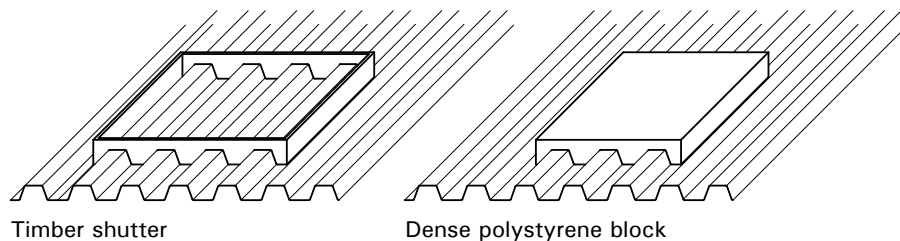

Figure 4.11 *Typical examples of boxing out openings*

For large openings, the supporting trimming steel should be in positioned prior to placing the decking. The opening should then be trimmed prior to casting the slab, as shown in Figure 4.12.

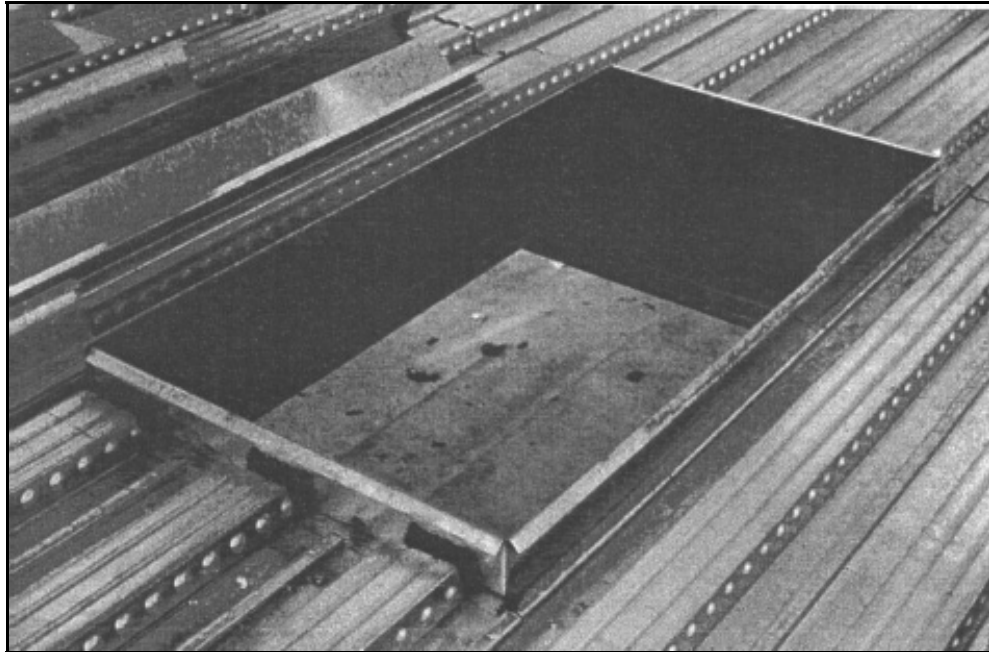

Figure 4.12 *A typical trimmed opening (immediately after deck laying, prior to fixing the edge protection and reinforcement around the opening)*

Cutting the slab after concreting (post-forming the openings) may cause a loss of bond between the concrete and the decking, and is not recommended. When post-forming is unavoidable, non-percussive cutting methods such as diamond core drills/saws should be adopted, so that the disturbance to the mechanical interlock between the decking and the concrete is kept to a minimum. The structural implications of the location and size of the opening need careful consideration, and should always be referred to the Structural Designer.

The need for extra reinforcement in the slab, or additional trimming steelwork, depends on the size of the opening. Requirements should be determined by the Structural Designer, who may be represented by a slab or steelwork specialist. The Structural Designer will identify reinforcement requirements on the contract drawings, and should be consulted if there are any doubts about the location of openings or the amount of reinforcement needed. Any additional reinforcement that may be required should be designed in accordance with BS EN 1992-1-1^[24] or BS 8110^[30]. Site operatives should be made aware that additional reinforcement is required around medium sized openings. This often takes the form of bars placed in the troughs of the decking adjacent to the opening, with additional transverse bars used to ‘smooth out’ the load transfer around the opening (see Figure 4.14). The distance between an opening and an unsupported edge should not be less than the greater of either 500 mm and the width of the opening. If the opening falls within the usual ‘effective breadth’ of concrete flange of any composite beams (typically span/8 each side of the beam centre line), the beam resistance should be checked assuming an appropriately reduced effective breadth of slab.

In the absence of any specific manufacturer’s guidance on the provision of extra reinforcement, it may be assumed that an effective system of ‘beam strips’ span the perimeter of the opening, as shown in Figure 4.13. The effective breadth of the beam strips should be taken as $d_o/2$, where d_o is the width of the opening in the direction transverse to the decking ribs. Only the concrete above the ribs is effective. The transverse beam strips are assumed to be simply supported, and span a distance of $1.5 d_o$. The longitudinal beam strips are designed to resist the load from the transverse beam strips, in addition to their own proportion of the loading. Extra reinforcement is provided within the ‘beam strips’ to suit the applied loading. This reinforcement often takes the form of bars placed in the troughs of the decking (see Figure 4.14). Additional transverse or diagonal bars may be used to improve load transfer around the opening. Reinforcement bars in these beam strips will need to extend at least an anchorage length beyond the centre line of the supporting beam.

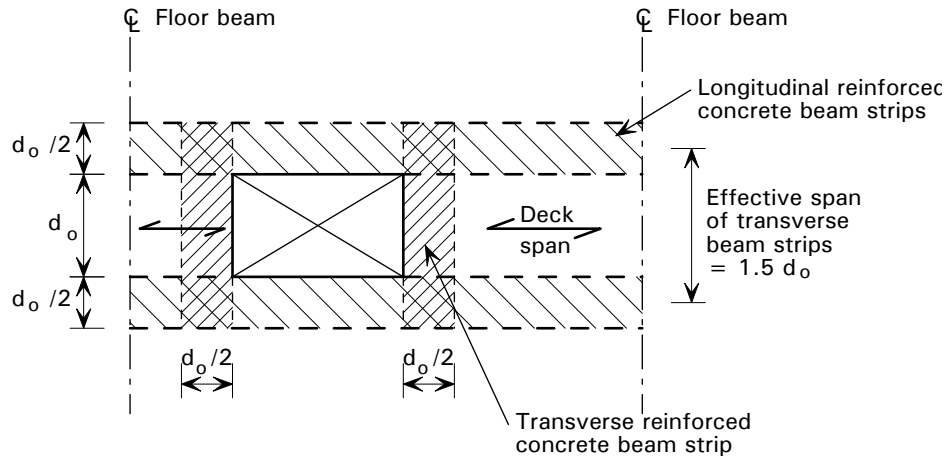

Figure 4.13 Load paths and beam strips around medium to large openings

Multiple openings in a floor may need to be considered as equivalent to one large opening, and the reinforcement should be designed accordingly.

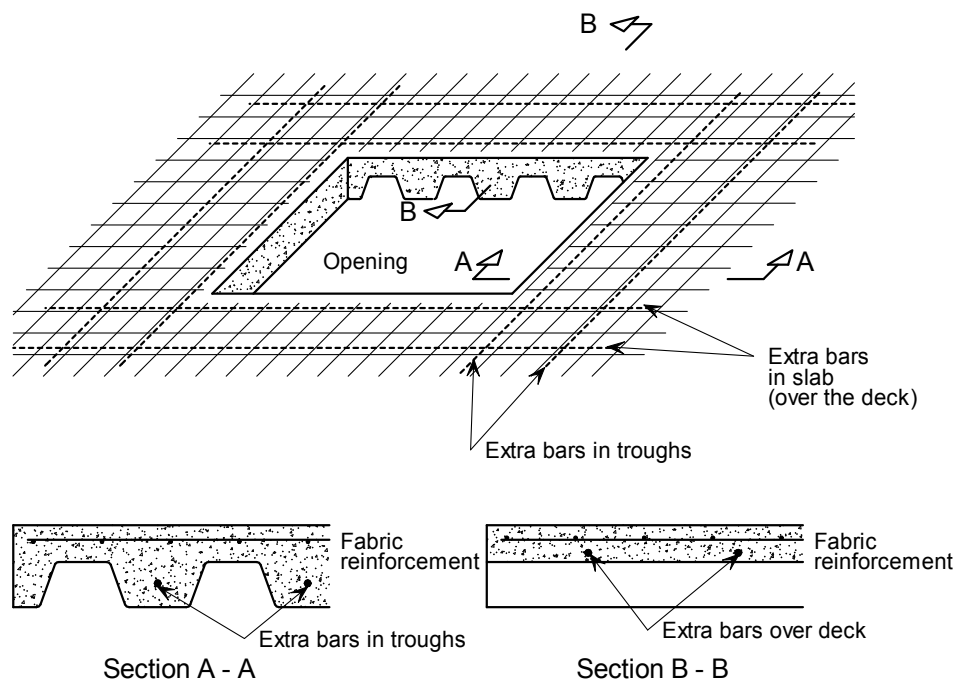

Figure 4.14 Typical reinforcement detailing around an opening

Slab edges

The edges of the floor are usually formed using 'edge trims' made from pressed strips of light gauge galvanized steel. Edge trim is delivered to site to the required depth and normally in standard 3.0 m long strips. The thickness of the steel used may vary with location, but is normally no more than 2 mm. The strips are cut to length on site to suit column centres. The trim is usually set out from the edge beam centre line (rather than the grid lines, which cannot be set out easily on site), as shown in Figure 4.15. The trim should be fixed in the same way as the decking. It should not be used as a tamping rail because it may be damaged.

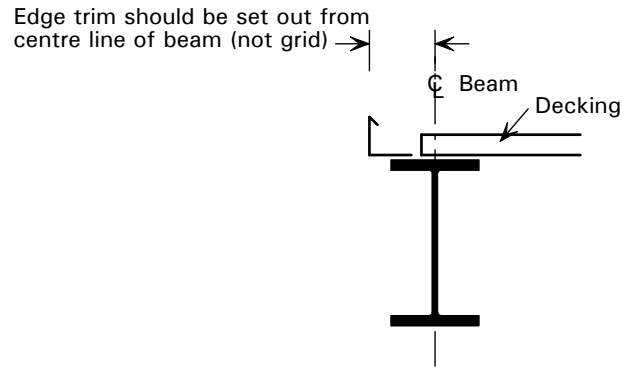

Figure 4.15 *Setting out of edge trim*

Straps are always specified to tie back the upper part of the trim at 0.6 m to 1 m spacing, depending on the slab depth and overhang. Typical details are given in Figure 4.16, covering two distinct cases. Where the decking (with transverse ribs) runs over the edge beam and cantilevers out a short distance, the edge trim can be fastened in the manner suggested in Figure 4.16(a). The cantilever projection should be no more than 600 mm, depending on the depth of the slab and deck type used.

The more difficult case is where the decking ribs run parallel to the edge beam, and the finished slab is required to project a short distance, so making the longitudinal edge of the sheet unsupported Figure 4.16(b). When the slab projection is more than approximately 200 mm (depending on the specific details), the edge trim should span between stub beams attached to the edge beam, as shown in Figure 4.16(c). These stub beams are usually less than 3 m apart, and should be designed and specified by the Structural Designer as part of the steelwork package. If stub beams are not provided in this case, then additional support to the edge of the decking, such as by propping from the floor beneath, may be required and this information **must** be highlighted in the information passed to the contractor. Non-standard edge trims (for example those used to support cladding, or those forming a curved edge) will require more accurate setting out procedures than standard trim.

Trims fixed to a curved edge are normally formed by cutting and bending the standard lengths to form a continuous faceted ‘curve’ with, typically, 300 mm straight sides.

Further information on how edge trims should be attached and supported is given in Reference 6.

Achievable tolerances for the position of the top of standard edge trims relative to the steelwork (after concreting) are ± 10 mm horizontally, and ± 5 mm vertically (see Figure 4.15). Tighter tolerances than these may need to be specified for edge trims that incorporate housings for cladding supports. It will also be necessary to ensure that these trims do not deflect excessively during concreting. The Structural Designer must specify requirements for any such ‘non-standard’ trims.

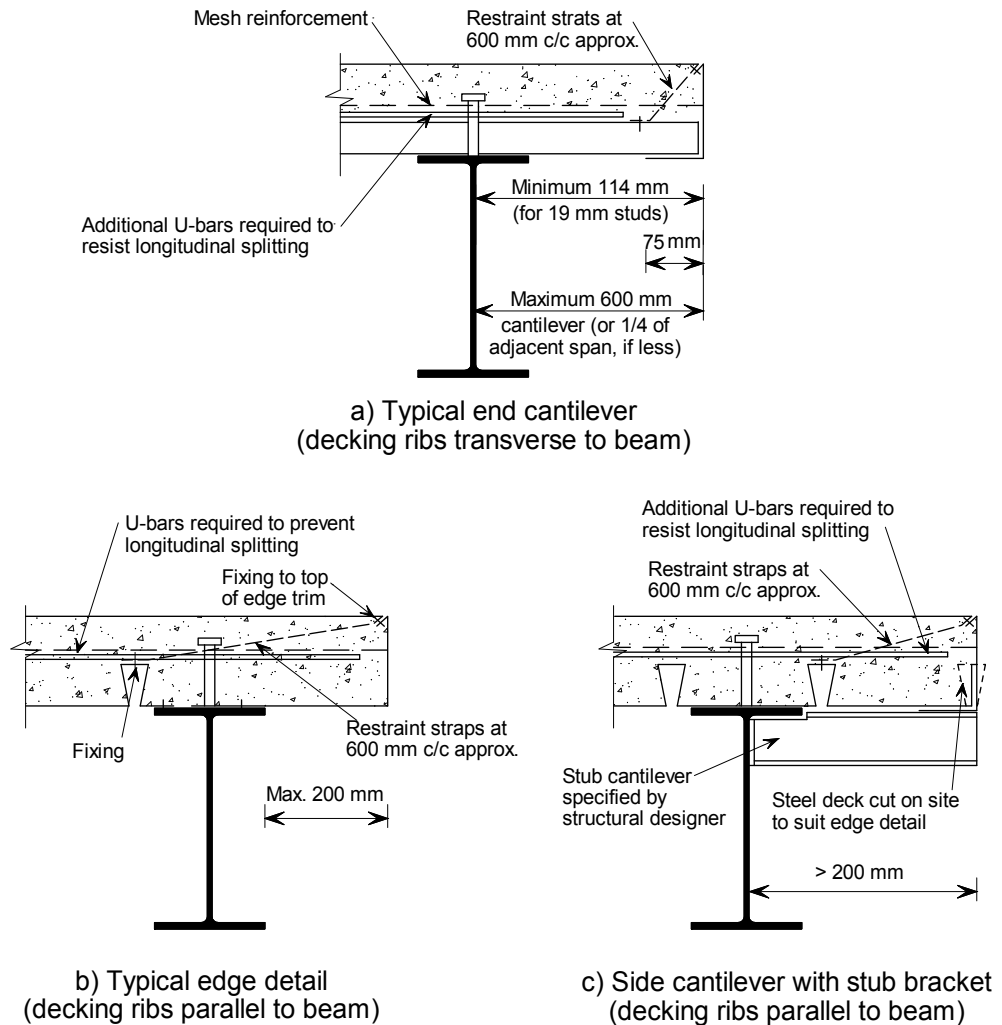

Figure 4.16 *Typical edge details*

4.2.7 Temporary supports

Decking is usually designed to be unpropped for spans up to 3 m for profiles up to 60 mm deep, and up to 4.5 m for profiles 80 mm deep. For longer spans temporary propping may be required, but this will depend on the depth of the concrete, the profile used and whether the decking is multiple or single spanning. The limitations of a particular decking should be checked with the manufacturer at an early stage so that any propping requirement can be planned. The structural designer should check whether beam deflections during construction and the method of levelling of the slab would lead to significant additional concrete loads (from concrete ponding) that have not been allowed for in the design of the structure and decking (see Section 4.1.3). Propping may be necessary to minimise ponding.

In general, traditional ‘shallow’ decking spanning greater than 4 m will require the propping system to be in place, braced and levelled, before placing the decking. SD225 deep decking will generally require such propping for spans greater than 7.5 m. Propping will reduce the deflections from the self-weight of the decking, which would otherwise be difficult to remove if props were installed after laying the decking. It will also minimise the risk of overloading the decking under loads during construction, e.g. from operatives and storage, but the implications of using design which requires propping should be

considered at an early stage, because it can have sequence and programming implications, and can preclude the use of safety netting. When temporary propping is positioned after the decking is placed, it is particularly important to check that the props are set in accordance with the Structural Designer's requirements, and that the increased weight due to concrete ponding is allowed for in the design of the propping system.

There may be small areas in a building where propping is necessary, even when the main areas of the floor remain unpropped. These propped areas may include bays that are in-filled after the removal of climbing cranes, or lift shafts which have non-standard span lengths. The decking layout drawings should show the extent and lines of temporary supports.

Normally, props are placed at either mid-span (one line of props) or at third points (2 lines of props) within a span. Isolated props should not be used, and all props should be suitably braced (in the direction of the line of the props and perpendicular to this) to prevent dislodgement during construction operations.

Props normally consist of lengths of timber and/or steel plates supported by adjustable length steel tubes ('Acrows'). The minimum bearing length of the timber and/or plates depends upon the thickness of the slab, the span length and the decking rib geometry. Bearing lengths are typically in the 75 to 100 mm range. The timber bearer should be continuous, and should extend the full width of the bay. The decking sheets should never be interrupted (cut) at the location of a temporary support, and the decking should not be fastened to the temporary supports. It is good practice to carry out a final check of the propping system before pouring the concrete.

A typical temporary support is shown in Figure 4.17. Props of this nature are normally placed about 1 m apart, according to the Structural Designer's requirements.



Figure 4.17 *Temporary support using an 'Acrow' props*

Props may be supported off the floor directly beneath the floor being concreted, but the designer should check that the design capacity of the lower floor is not exceeded (the supporting floor should achieve its design strength before props

are installed). If the lower floor does not have sufficient resistance, further 'back' propping will be needed (i.e. using props to support the floor that is supporting the props). Props should never be placed directly on the decking alone as this could result in localised buckling of the deck. Further guidance on back propping can be found in Reference 34.

Props should not be removed until the floor has reached 75% of its design strength. This is normally achieved in 7 to 8 days, but the Structural Designer should be consulted specifically before removal, unless general guidance has already been given. Where crack control is essential, props should not be removed until the floor has achieved its specified strength.

Other temporary support details may be needed for special situations, such as end supports in refurbishment projects or where there are concrete encased beams. Particular care should be taken with non-standard details to ensure that the sequencing of the construction is practicable. A typical detail for the temporary support of the decking at an encased beam is shown in Figure 4.18. In this case, the decking is supported initially off the steel beam, and a temporary prop is inserted under the decking close to the beam. This must be of sufficient width to avoid crushing of the decking during concreting (see Section 4.1.4). The decking is then cut back to allow access for the reinforcement and the shuttering to be positioned, and the concrete to be poured. This detail is only suitable for re-entrant decking because the decking can interlock into the concrete by the 'dovetails', without needing support underneath in the permanent condition. The decking cannot contribute to the shear resistance of the finished slab. Use of this detail should be confirmed by the Structural Designer and indicated on the drawings.

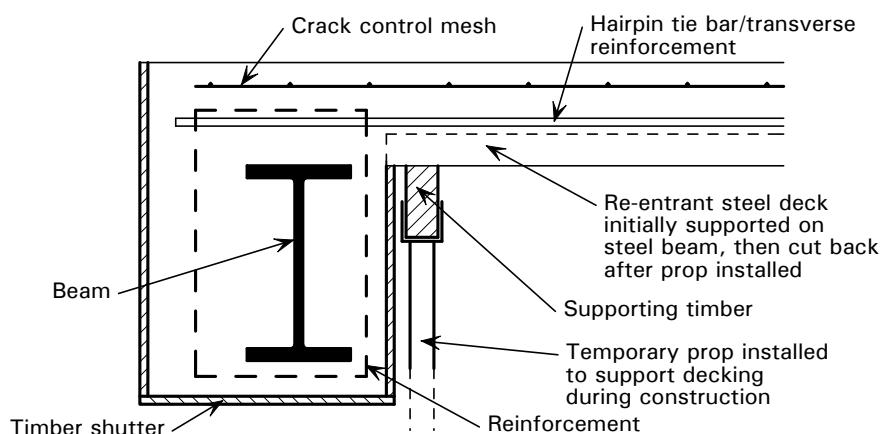

Figure 4.18 *Special temporary support detail for re-entrant decking on a concrete-encased beam*

4.2.8 Attachments

Hangers

The best way to eliminate the hazardous activity of post-drilling concrete to attach services is to use hangers, and designers are encouraged to specify them. Many decking profiles have re-entrant slots into which proprietary wedges can be inserted to receive threaded rods. The rods serve as hangers to the services, and they have a safe load-carrying capacity of, typically, 100 kg to 200 kg each. Some examples of these attachments are shown in Figure 4.19.



A wedge attachment

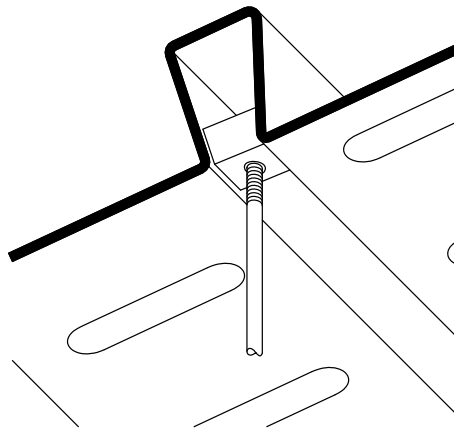

An alternative wedge attachment

Figure 4.19 *Examples of fixings for ceilings and services*

Designers or Architects wishing to make use of these attachments should seek information, including safe load capacities, from the decking supplier. For services that are too heavy for the capability of the hangers, it may be necessary to use drilled expanding anchor fixings into the composite slab (taking care to ensure that the resistance of the fixing is appropriate for this type of use).

For detailed information on the interface between the services and the floor, refer to *Interfaces: Design of Steel framed buildings for service integration*^[35].

Cladding supports

Brackets cast in to the edge of the slab may be used to support the cladding. These may form part of a proprietary edge trim. Even though this may need to be set out more accurately on site than the standard edge trim, the support system should be co-ordinated early during the design process to allow for horizontal deviations in the edge of slab position of at least ± 25 mm (more for high rise buildings). Such an allowance is necessary because not only may the allowed tolerances for the cladding be considerably more stringent than those for the frame, but also that the brackets may move during concreting. An example of a typical stainless steel brickwork support arrangement is shown in Figure 4.20.

As an alternative to cast-in brackets, drilled fixings may be used to achieve greater accuracy and require the use of power tools. Drilling for these fixings may, however, be more time-consuming. For further information on cladding attachments see *Interfaces: Curtain wall connections to steel frames*^[36].

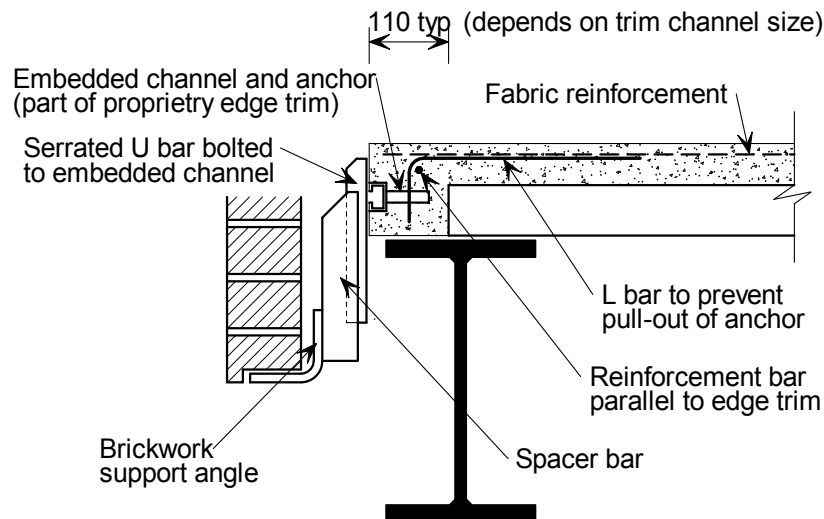

Figure 4.20 Typical steel brickwork support

Cladding fixing brackets should be provided with provision for adjustment, in recognition of different tolerance requirements for the slab edge and the cladding. This may avoid problems and additional cost on site.

4.3 Acoustic insulation

Building designers should consider two basic ‘types’ of sound transmission; airborne and impact. The acoustic insulation (attenuation) of both types of sound, and particularly airborne sound, is partly related to the mass (or weight) of the element through which the sound is passing. It is also affected by the presence of any ‘soft’ layers, which increase the sound absorption.

High levels of sound insulation are typically required in:

- Multi-occupancy residential buildings
- Hotels
- Schools and other education-related buildings
- Hospitals and other health-related buildings.

For composite floors with shallow decking, a bare composite slab will normally provide about the same degree of acoustic insulation as a reinforced concrete slab with a thickness equal to the average thickness of the composite slab. However, the floor should not be considered as an element in isolation because the acoustic performance of the walls, and the junction details between the walls and floors, also need consideration. The junctions need to be detailed to minimise sound which may travel around the floor; known as flanking sound. Further guidance on this is provided in SCI Publication P372^[37]. Approved Document E to The Building Regulations^[38] requires residential buildings to undergo pre-completion acoustic testing to demonstrate compliance unless the walls, floors and their interfaces have been constructed in accordance with ‘Robust Details’^[39].

Enhancing the acoustic performance of the floor by adding mass is not very efficient and is not always practical. This is particularly true for impact sound.

A much more effective means of enhancing sound attenuation is by the use of layers above and below the floor slab. A 'resilient layer' of material applied above the bare slab and beneath the walking surface is an effective way of reducing the impact sound transmission through the floor. The walking surface material, such as a screed or chipboard, forms a 'floating layer' above the resilient layer; the sound energy is absorbed by the resilient layer rather than being transmitted through the floor. A ceiling layer suspended below the floor slab will reduce airborne and impact sound transmission. In addition, the impact sound transmission can be reduced by suspending the ceiling on resilient bars, which reduces the sound transfer from the slab. A wide range of proprietary acoustic floor and ceiling systems are available which incorporate these features.

As a guide to the acoustic performance of typical composite floor constructions, the attenuation that can be expected is given in Table 4.10. All the values given in the table are for normal weight concrete, which is recommended for dwellings and buildings where acoustic insulation is important. Lightweight concrete will generally give slightly less sound insulation than normal weight concrete.

Details of a shallow deck composite floor and a deep deck composite floor that both comply with Robust Details are shown in Figure 4.21 and Figure 4.22 respectively.

4.4 Health & Safety

Revised CDM Regulations came into force in 2007 and were published with an associated Approved Code of Practice (ACoP)^[4]. The ACoP should be read in conjunction with the Regulations, as it has special legal status and gives advice on how to comply with the law. These are the most important new regulations affecting safety in construction to be published in recent years. Their primary thrust is to ensure that structures can be constructed, used and demolished safely. 'Use' in this context relates to operations such as maintenance, redecoration, repair and cleaning.

One of the most significant features of the Regulations is that designers are now required to concern themselves with construction safety. They must give adequate regard to 'foreseeable' hazards and, by implication, the designer is expected to have a sound appreciation of the hazards that may be involved in the project. This does not mean that the designer is expected to take responsibility for all hazards that will eventually arise on site. A designer cannot prevent unsafe practices taking place, and the word 'foreseeable' acknowledges that some hazards cannot be anticipated. The Contractor remains responsible for health and safety on site and this responsibility is not diminished by the designer's regard to the foreseeable hazards.

Another area where the designer has significant influence is in the specification of components, which falls within the definition of design according to the Regulations. The selection of materials, equipment, etc. must be given equal attention to that of the construction method itself.

Table 4.10 Site test data for composite floors

Form of Floor Construction	Sound pressure level (dB)	
	Airborne Sound Attenuation	Impact Sound Level
	$D_{nT,w} + C_{tr}$ (dB)	$L'_{nT,w}$ (dB)
Approved Document E requirement for purpose built dwellings ^[38]	≥ 45	≤ 62
Shallow Deck Floors		
An 18 mm chipboard walking surface over 25 mm of dense mineral wool over a 175 mm slab on a 60 mm trapezoidal deck. A 12.5 mm plasterboard ceiling suspended from the slab on a metal framed grid.	55	43
An 18 mm MDF walking surface over a 10 mm dense fibre resilient layer over a 200 mm slab on a re-entrant deck. A 30 mm (2 x 15) plasterboard ceiling suspended from the slab on a metal framed grid.	56	34
A 70 mm screed on 5 mm foam resilient layer over a 150 mm slab on 50 mm re-entrant deck. A 12.5 mm plasterboard ceiling suspended from the slab on a metal framed grid with 85 mm of mineral wool in the ceiling void.	56	40
A 18 mm chipboard walking surface supported on softwood timber battens on a 25 mm acoustic quilt over a 150 mm slab on a re-entrant deck. A 25 mm (2 x 12.5) plasterboard ceiling suspended from the slab on a metal framed grid.	60	34
Deep Deck Floors		
An 18 mm chipboard walking surface supported on softwood timber battens with resilient strips over a 13 mm mineral fibre quilt over a 300 mm deep slab. A 12.5 mm plasterboard ceiling fixed to timber battens fixed to the underside of the slab.	54	48
An 18 mm chipboard walking surface over 30 mm of dense mineral wool over a 300 mm deep slab. A 12.5 mm plasterboard ceiling suspended from the slab on a metal framed grid.	54	43
An 18 mm chipboard walking surface supported on softwood timber battens with resilient strips over a 300 mm deep slab. A 12.5 mm plasterboard ceiling suspended from the slab on a metal framed grid.	55	42
A 55 mm screed over a 5 mm foam resilient layer over a 300 mm deep slab. A 12.5 mm plasterboard ceiling suspended from the slab on a metal framed grid.	57	45

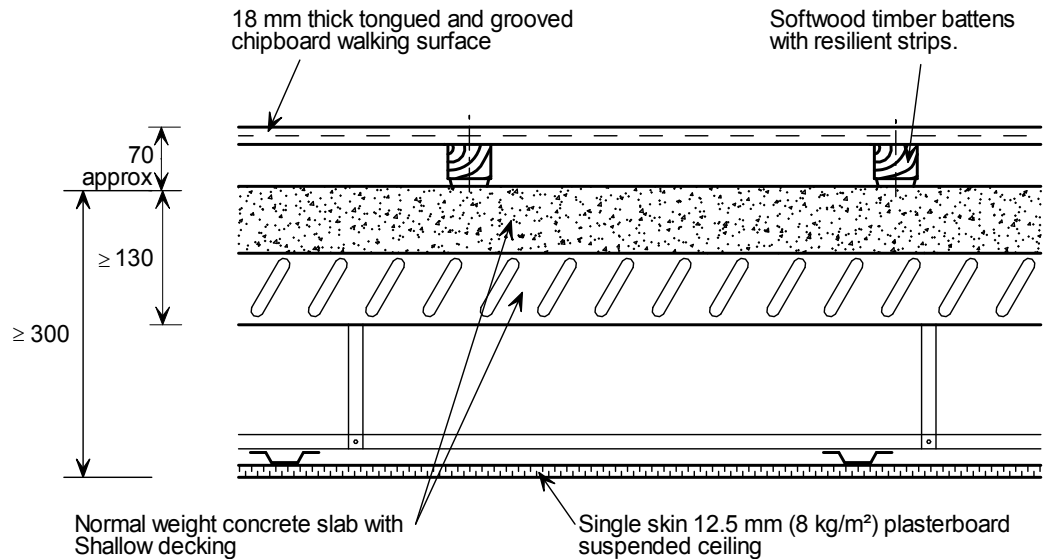

Figure 4.21 Typical shallow composite slab with a battened resilient floor system (classified as a Robust Detail)

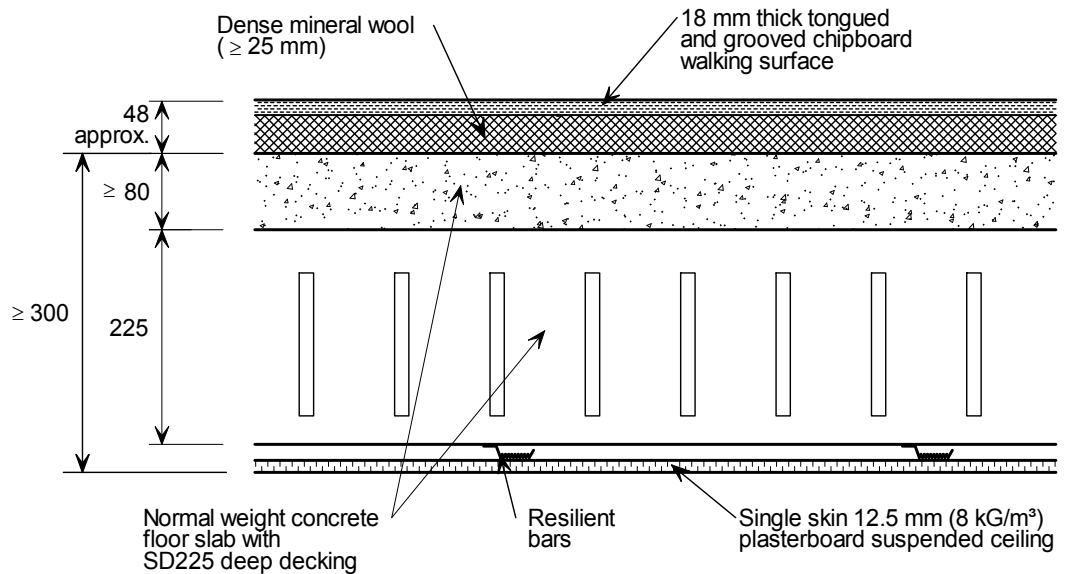

Figure 4.22 Composite slab with deep decking and a layered resilient floor system (classified as a Robust Detail)

The designer is obliged to follow the same hierarchy of measures whether considering the construction process or the specification of components, namely to avoid hazards, reduce their impact, or protect people from their consequences. Designers may assume (as indeed the ACoP requires) that contractors will be competent, i.e. not only capable of providing quality work, but also experienced in the day-to-day hazards associated with that work. For example, designers may assume that decking layers are experienced specialists

who are aware of the hazards of working at height, and used to managing the associated risks by adopting best practice in laying techniques.

Nevertheless, designers must consider whether there are any features of the design itself, or the way in which it would be constructed, which are unusual, or unduly onerous, for operatives. Features falling into one of these categories may include the specification of items which are difficult to handle and locate, such as excessively long and heavy decking sheets. Such features may be avoided by changing the steelwork layout, propping arrangements, etc. Another feature falling into this category is the need for propping of the decking during construction. If, on the basis of information given in a load-span table, the designer knows that there will be a need to prop the chosen decking in order to satisfy the load and span requirements, this information must be clearly communicated to the relevant parties, preferably on the drawings.

A number of ways to reduce ‘general’ risks and afford greater protection to those working at height during the deck installation are recommended in the good practice guidance given in Reference 6. They include such measures as edge protection and the use of fall arrest equipment. A list of common hazards that are more specific to floor construction using steel decking, and the measures to control the risks associated with them, are shown in Table 4.11.

Table 4.11 *Common hazards associated with floor construction using metal decking and potential design and site control measures*

Hazard	Design/Site Control Measures
Falling through decking - due to inadequate resistance of decking	Check the decking for the erection case.
Falling through decking - due to inadequate support	Allow for adequate bearing. Minimise the use of propping. Highlight the need to ensure the propping arrangement is in place and of adequate construction. Supply propping loads
Falling through penetrations in decking	Create openings by ‘boxing out’ and cutting out later. Minimise penetration (liaise with services engineer)
Contact with hot particles during stud welding	Wear appropriate protection when stud welding, and barrier and/or screen areas below or in proximity
Collapse of decking from overload during concreting	Check decking for erection loads given in BS EN 1991-1-6 or BS 5950-Part 4
Collapse of decking due to overload from bad storage of materials.	Place stored materials directly over, or close to, support beams, and distribute their weight over the decking ribs using timbers

4.5 Further reading

The references given below mainly relate to slab design. See Section 5.4 for additional design guidance related more to beams. (For information on authors and publishers, see Section 8, References.)

Concrete Society Technical Report No. 63, 2007 - Guidance for the design of steel-fibre-reinforced concrete^[40].

This publication summarises the range of applications for steel-fibre-reinforced concrete and includes practical aspects such as production and quality control.

Concrete Society Technical Report No. 65, 2007 - Guidance on the use of macro-synthetic fibre reinforced concrete^[41].

This publication reviews the current range of applications for Macro-synthetic Fibre Reinforced Concrete and gives guidance on quality control.

Interfaces: Curtain wall systems for steel frames (P101)^[36]

This outlines the main considerations in the design of a curtain wall attachment system, and reviews some of the systems available for steel framed buildings.

Interfaces: Composite floor systems (P166)^[42]

This book provides information on most aspects relating to the design of composite floors. It is particularly useful in that it covers both conventional composite floors with shallow decking and slim floors (with deep decking). A comprehensive set of worked examples of the design of floor beams is included.

Design of composite slabs and beams with steel decking (P055)^[43]

This provides the theoretical aspects of the design of composite beams with shallow decking. It includes a comprehensive series of design tables for common loading and span arrangements, and a worked example.

Acoustic detailing for steel construction (P372)^[37]

This guide explains the principles of acoustics in a very readable way. Sound insulation values are given for many examples of floor and wall construction, and typical details are recommended which are compatible with the *Robust Details Handbook*^[39].

Advisory Desk

The following 'Advisory Desk' items, published in New Steel Construction and available on www.steelbiz.org, provide further information relevant to this Section:

AD 150, Vol 1, December 1993^[45], *Composite floors - wheel loads for fork lift trucks*. This note gives a procedure for checking the behaviour of slabs under heavy point loading. [Further advice is given in BS EN 1994-1-1, clause 9.4.3.]

AD 163, Vol 2, December 1994^[20], *Provision for water vapour release in composite slabs*. This note explains the problems sometimes associated with water vapour release in composite roof slabs. It is suggested that perforated roof felt may be used, but the use of perforated decking is not recommended.

AD 247, Vol 9, March 2001^[9], *Use of composite construction in an aggressive environment*. This note gives advice on improving the corrosion resistance of decking and beams for an aggressive environment. It recommends using coated steel or additional paint protection for decking, and discusses the advantages and disadvantages of using shot-fired studs or pre-welded studs for beams.

5 DESIGN OF COMPOSITE BEAMS

This Section provides information about design principles and procedures, codified design rules, and guidance on good practice in design and detailing. It (along with Section 4) is aimed primarily at the Structural Designer, and any Delegated Designers. Summary boxes are used to highlight particular issues of good practice, or things that the designer should beware of.

Composite beams typically consist of steel 'I' sections acting structurally with a concrete slab by means of shear connectors attached to the top flange of the steel section, as shown in Figure 5.1. An effective width of slab is taken as acting as part of the composite section on either side of the centreline. Fabric reinforcement is ideally placed below the head of the studs; its main role, possibly supplemented by individual bars, is to act as transverse reinforcement in order to transfer the forces between the shear connectors and the slab. Alternatively, fibre reinforcement may be used to fulfil this role. Fabric or fibre reinforcement may also serve as a means of controlling crack widths. The beams are generally designed to be simply supported.

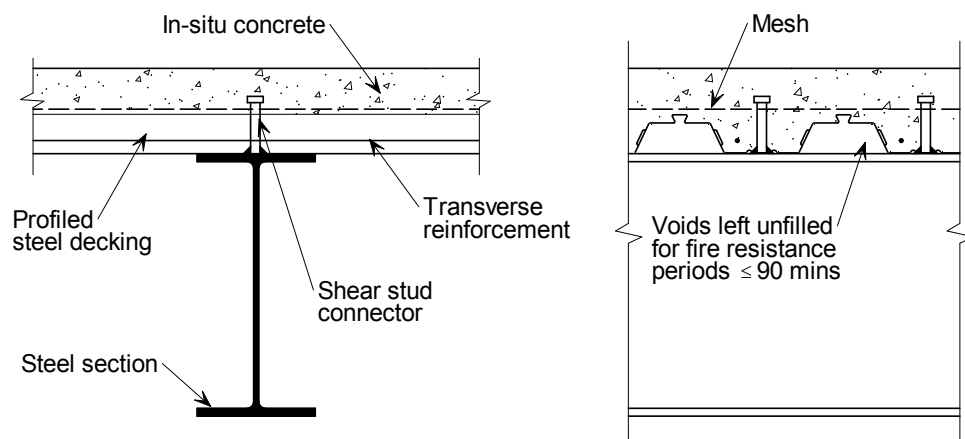

Figure 5.1 Typical cross-section through a composite beam

The composite action developed between the steel beam and concrete slab significantly increases the load carrying capacity and stiffness of the beam by factors of up to 2 and 3.5 respectively^[46]. These benefits can result in significant savings in steel weight and/or structural floor depth.

It is often found that the size of the steel section is governed by serviceability considerations because composite beams tend to be used for long span applications (in excess of 9 m). This makes deflection and dynamic criteria more likely to be critical. Controlling deflections is particularly important where brittle ceiling finishes are specified, or for edge beams, where excessive deflections can damage the cladding.

Designers should note that where edge beams are designed as composite beams, care is required to ensure that the decking, edge trim, shear connector, slab edge and reinforcement details are practicable. Edge beams are sometimes designed non-compositely to avoid transverse reinforcement requirements, which may result in problems of reinforcement congestion.

5.1 Construction stage

The steel sections are normally designed to be unropped during construction, and must be sized to support the self-weight of the slab, and other construction loads, in their non-composite state. Design is generally in accordance with either BS EN 1993-1-1^[47] or BS 5950-1.

The weight of extra concrete from ponding of the slab should be allowed for in the design of the beams when the deflection of the decking under the wet weight of the concrete exceeds one tenth of the depth of the slab, in accordance with both BS EN 1994-1-1 and BS 5950-4. Careful consideration should be given to the correct allowance for the weight of the concrete when ‘mass flood’ levelling techniques are adopted – see Section 6.2.1. As well as checking the resistance of the steel beams, this will involve an assessment of their stiffness. Beams that are not suitably stiff will deflect excessively during concrete placement, and the extra concrete should be allowed for in the design.

When designing to the Eurocodes, the construction load is defined in BS EN 1991-1-6 and is taken as the same construction load as for designing the decking, as described in Section 4.1.2. The self weight of the wet concrete is treated as a variable load. The construction loading is significantly more onerous for beams than previous UK practice and, at the time of writing, consideration is being given to address this.

When designing to BS 5950, the construction load should be taken as an ‘imposed load’ of not less than 0.5 kN/m² applied uniformly over the supported area. The construction loading should be applied in addition to the self weight of the concrete, reinforcement and decking. This non-composite check may dictate the final choice of section size if subsequent imposed loads are low.

To use a steel beam economically, the top (compression) flange needs to be restrained laterally. The restraint provided by the decking to the beams depends on the decking orientation and the fixings. The restraint provided by decking spanning in a direction parallel to a beam is normally assumed to be negligible, but decking spanning perpendicularly to a beam can provide restraint if it is adequately connected. In this latter case, continuous lateral restraint occurs when thru-deck welded shear connectors are provided (irrespective of other fixings), but when there are no shear connectors, restraint is limited by the resistance of the fixings. This will depend not only on the shear resistance of an individual fixing (typically, 0.8 kN to 4.0 kN, according to the type of fixing), but also on their spacing along the beam. The Structural Designer should ensure that the restraint assumed in the design is provided by the fixing arrangement; guidance on the force that must be resisted is given in the SCI publication *Lateral stability of steel beams and columns* ^[48] and BS EN 1993-1-1 (or BS 5950-1).

Check that the steel beam size chosen is capable of supporting the wet weight of the concrete, and other construction loads, in its non-composite state.

Check that beam deflections during construction will not lead to significant additional concrete loads (due to ponding) that have not been allowed for in the design.

The decking will only provide lateral restraint to the beams during construction if the resistance of the fixings is adequate, and where the decking ribs run perpendicular to the beams.

5.2 Composite stage

5.2.1 Design for resistance

Composite beams are generally designed in accordance with either BS EN 1994-1-1 or BS 5950-3. In both cases, the bending resistance of the section is normally evaluated using ‘plastic’ principles (provided the cross section will not be subject to local buckling). The calculated resistance is then independent of the order of loading, i.e. whether the beam is propped or unpropped during construction. The resistance should be adequate for the maximum total design moment at the ultimate limit state.

The plastic moment resistance is calculated using idealised rectangular stress blocks, as shown in Figure 5.2. In BS EN 1994-1-1 it is assumed that stresses of f_{yd} and $0.85 f_{cd}$ can be achieved in the steel and concrete respectively, where f_{yd} ($=f_y/\gamma_{M0}$) is the design yield strength of the steel and $0.85 f_{cd}$ is the bending compression resistance of the concrete. It is 0.85 times the design cylinder strength of the concrete f_{cd} , where $f_{cd}=f_{ck}/\gamma_c$. Equivalent strengths in BS 5950 are p_y for the design yield strength of the steel and $0.45 f_{cu}$ for the design bending compression strength of the concrete (where f_{cu} is the cube strength of the concrete).

The plastic neutral axis may fall within the depth of either the slab or steel section, depending on the relative areas of these two components.

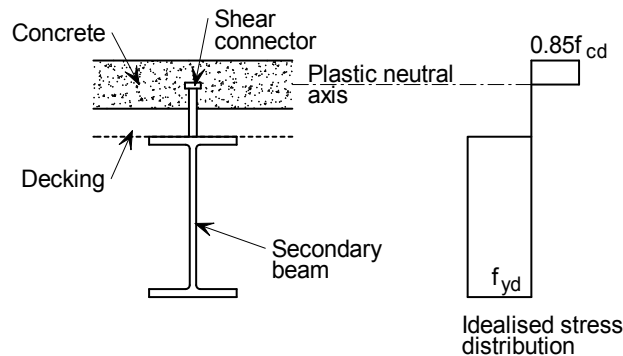

Figure 5.2 *Plastic analysis of composite section (using BS EN 1994-1-1 notation)*

The area of concrete in compression is limited by its effective breadth. This breadth varies along the length of a beam, as shown schematically in Figure 5.3. Its form depends on the type of loading, and the end conditions (simply supported or continuous). However, a simpler form may be assumed for design. In BS EN 1994-1-1, the effective breadth is defined as constant for the middle portion of the span and tapering towards each end, as shown in Figure 5.3. The distance between centres of pairs of shear connectors, b_0 , is also included. However, for the serviceability limit state, a constant effective breadth can be assumed to act over the entire span, based on the mid-span value. In BS 5950-3, the effective breadth is a constant value for a simply-supported beam with decking perpendicular to the beam. For both BS 5950-3

and BS EN 1994-1-1 the maximum value of the effective breadth is $\text{span}/8$ on each side of the centre-line of the beam for both serviceability conditions and for the ultimate limit state. As well as considering this limit, the width assumed in design must not exceed the actual slab width available. This is particularly relevant for edge beams and beams adjacent to openings, where there may be only a narrow width of slab on one side.

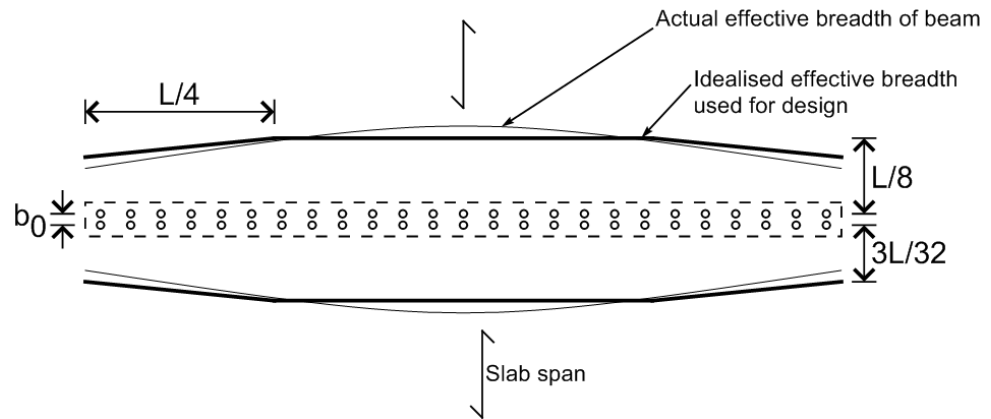

Figure 5.3 *Effective breadth profile of a simply supported beam according to BS EN 1994-1-1*

The compressive area of the concrete also depends on the orientation of the decking. When the decking ribs run perpendicular to the beam, the concrete contained within the depth of the decking must be neglected (see Figure 5.4(a)). When the decking ribs run parallel to the beam, the total cross-sectional area of the concrete may be considered, provided that it lies above the neutral axis of the composite section (Figure 5.4(b)).

The stress blocks that can be generated in the steel and concrete, and used to calculate the moment resistance, may be limited by the amount of longitudinal shear force that can be transferred between the materials at their interface. If this limit governs, it is called 'partial interaction' (see Section 5.3.3).

It is assumed that in both BS EN 1994-1-1 and BS 5950-3 all of the vertical shear force applied to the beam is resisted by the steel section alone. Design checks should therefore be in accordance with BS EN 1994-1-1 or BS 5950-3, which give guidance on the consideration of combined bending and shear. In addition, the width of the top flange of the steel section must be sufficient to ensure that the decking does not fail in bearing over the beam.

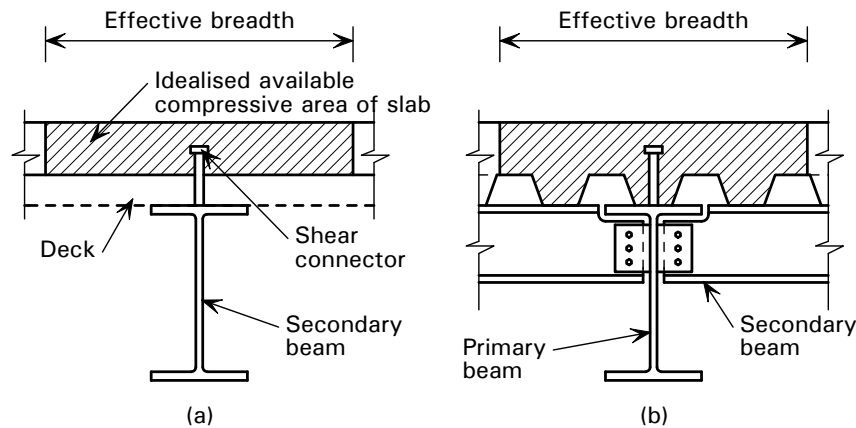

Figure 5.4 Composite beams incorporating composite slabs. (a) Deck perpendicular to secondary beam. (b) Deck parallel to primary beam

The concrete adjacent to the steel beam forms a structural flange, and the presence of openings in the slab will therefore influence the performance of the beam.

Avoid placing slab openings next to beams (within the effective flange width) wherever possible. If such openings cannot be avoided, their effect must be included in the beam design.

5.2.2 Design for serviceability

Deflections

Composite beams are generally shallower (for any given span and loading) than non-composite beams, and they are used commonly in long span applications. Consequently, deflections are often critical. BS EN 1990^[49] (and BS 5950-1) recommends that deflections should not affect the appearance, the comfort of users or the functioning of the structure.

In addition to the ‘traditional’ deflection check under imposed loads, it is also prudent to check deflections due to the following:

- Total (in-service) loads – the combined dead and imposed loads should be considered to ensure that floor curvatures will not be unacceptable (see comments below on deflection limits). This is particularly important for long spans if there is limited depth available in the zone for under-floor services.
- Construction loads – although not a serviceability deflection limit, it is necessary to check that excessive concrete ponding will not apply significant extra loading to the structure.

For edge beams supporting cladding, it is important that the deflections are checked under cladding and imposed floor loads to ensure that the deflection of the beams does not compromise the performance of the cladding.

‘Uncracked’ elastic section properties should be used to calculate the deflection of simply supported beams (the total area of concrete within the effective flange width is considered, even that part which in reality will be cracked in tension). A transformed section is used; the effective width of the slab is reduced using a

modular ratio equal to the elastic modulus of the steel divided by that of the concrete. The effect of creep of the concrete is taken into account by choosing a modular ratio between one based on short term concrete properties and one based on long term properties, according to the mix of long and short term loading.

When designing to BS EN 1994-1-1, the increased flexibility of the composite beam caused by greater slippage between the concrete slab and the steel section when using partial shear connection may be ignored if the degree of shear connection is not below 50%. However, BS 5950-3 requires an additional deflection to be included using a modification factor.

For the calculation of deflections where props are used, all the loads are applied to the composite section.

Deflection limits for beams subject to imposed load are recommended in the National Annex to BS EN 1993-1-1 (or BS 5950-1). As a more comprehensive guide, the deflection limits given in Table 5.1 may be considered in design.

Table 5.1 *Suggested deflection limits for composite beams*

Beam Type	Load Case	Limit	Absolute Limit (mm)
Internal beams	Imposed load	Span/360	To suit finishes
	Total load	Span/200	To suit finishes
	Dead load at construction stage	–	25 [‡]
Edge beams supporting both floor and cladding	Imposed load	Span/500	To suit cladding
Edge beams supporting both floor and cladding	Imposed load + cladding	Span/360	To suit finishes
	Total load	Span/250	To suit cladding
Edge beams supporting cladding only	Cladding weight	Span/500	To suit cladding

Notes:

‡ Although not a serviceability criterion, this is to limit the additional load due to ponding of the concrete, consequent on beam deflection.

Where dead load deflections are excessive, pre-cambering may be appropriate (this is normally only adopted for beams longer than 10 m). However, the pre-camber required may be difficult to determine accurately; for example, the stiffening effect of the end connections may be significant, so some pre-camber may remain after casting, and the depth of the slab may not be as intended at the critical point of mid-span. Therefore, a general rule of thumb is to design any pre-cambering to eliminate no more than two thirds of the dead load deflection. In some situations, large amounts of pre-camber may possibly hinder the laying of decking.

Further information on methods of calculating deflections are given in *Design of composite slabs and beams with steel decking*^[43]. For the assessment of beam with web openings, additional guidance may be found in *Design of beams with large web openings for services*^[50].

The deflection limits used in design should be chosen to suit the building details.

Pre-cambering can be used to limit beam deflections under dead load. Assessing the amount of pre-camber needed may prove difficult, and calculations should take into account the likely stiffness of the connections.

Irreversible deformation

In BS EN 1994-1-1 there is no specific requirement to limit stresses at the serviceability limit state (see clause 7.2.2). In BS 5950-3, the stresses in simply supported composite beams at the serviceability limit state, calculated using elastic principles, are limited to p_y in the bottom fibres of the steel section, and $0.5 f_{cu}$ in the concrete slab. Full shear connection, with negligible slip, may be assumed when calculating these stresses. Any part of the concrete in tension should be neglected when calculating stresses ('cracked' section properties should be assumed – unlike the procedure for calculating deflections, when uncracked properties may be assumed). A similar limitation could be applied when designing to BS EN 1994-1-1, whereby the steel stress would be limited to f_y and the concrete stress to $0.63 f_{ck}$.

In unpropped construction, the stresses should be calculated first for the non-composite section subjected to the loading at the construction stage, and then those for the composite section should be added. In propped construction, the stresses due to the construction loading are often ignored.

Dynamic sensitivity

Traditionally, the parameter used to assess the dynamic sensitivity of a floor is its natural frequency. This allows a simple assessment of what is, in reality, very complex behaviour. A frequency of 4 Hz is a commonly accepted lower limit for the natural frequency of an individual composite floor beam, as this will generally mean that the frequency of the entire floor system is greater than 3 Hz, and therefore ensure that excitation activities do not occur at a frequency that coincides with that of the floor. A higher frequency limit may be appropriate for applications such as dance floors and gymnasia.

The natural frequency of a floor beam may be determined from the approximate formula $f = 18/\sqrt{\delta}$, where δ is the static deflection (in millimetres) resulting from the application of the self-weight of the floor, plus that of the ceiling and finishes, plus 10% of the imposed loading applied to the composite beam. Partitions tend to increase the damping and stiffness of the structure, and are not included in the loading.

Floors are likely to be more 'lively' in situations where there is a grid of primary beams and secondary beams. In these cases, the cumulative deflection of the slab, secondary beams and primary beams (i.e. the total deflection in the middle of the slab) should be assessed, and a combined floor frequency calculated. A method for determining the combined frequency is set out in *Design of floors for vibration: A new approach*^[51]. This publication also includes methods for determining the likely accelerations of a floor when subjected to vibration, in terms of Response Factors, and it is recommended that this more detailed analysis is used to assess the dynamic sensitivity of a floor.

Long span applications, for which composite beams are often used on account of their excellent resistance and stiffness characteristics, often have a relatively low natural frequency. However, they also tend to have a high effective mass. The consequence of this is that the inertia of the floor relative to the impacting dynamic loads is large, so that floor accelerations (which are what dictate

occupant comfort) remain acceptably low. This means that even if the natural frequency limit is not satisfied, a full calculation of the floor response may show it to be satisfactory. Further information may be found in Reference 51.

5.2.3 Design for fire resistance

Typically, composite beams are design to achieve the required fire resistance by applying fire protection materials. Three methods of protection are commonly used; boards, sprays and intumescent coatings. Fire protection adds to the cost of the structural frame and has implications on the construction programme, as another trade has to be accommodated in the construction programme. There are alternative methods of design available which limit the extent of fire protection required on composite floor plates, as described in SCI publication, P288^[52].

It is also possible to take the fire protection operations for beams off-site. Off-site intumescent coatings are becoming increasingly popular because, unlike traditional forms of protection (which are applied on site), the operation is not on the critical path and is not affected by the weather. Although better handling and storage of the sections is required with offsite coatings, any slight damage can be touched up easily. Through-deck stud welding on site will have an affect on the intumescent coating, but does not prohibit the use of off-site protection of composite beams. Further information is available in *Structural fire design: Offsite applied thin film intumescent coatings*^[53].

For composite beams that are to be fire protected, a ‘critical temperature’ needs to be established in order to enable the required thickness of fire protection to be determined. Methods of determining the failure temperatures are provided in BS EN 1994-1-2^[28] and BS 5950-8^[11]. The terminology used to describe these methods is different in each Standard but they both provide a calculation model for determining the relationship between beam failure temperature and the load applied in fire conditions. The thermal properties of proprietary fire protection systems are not readily available in the public domain. However, Table 5.2 provides an initial estimate for the critical temperature for composite beams subject to bending. More comprehensive information is given in the NA to BS EN 1994-1-2 and in BS 5950-8. The load level at the fire limit state η_{fi} should be calculated as follows:

$$\eta_{fi} = \frac{E_{fi,d,t}}{R_d}$$

where $E_{fi,d,t}$ is the design value of the effects of actions at the fire limit state and R_d is the design resistance at normal temperature.

For beams designed to the Eurocodes, it is recommend that the resistance of the composite beam is verified by calculation of the moment resistance $M_{fi,Rd}$ using the procedure given in BS EN1994-1-2 §4.3.4.2, which is described in more detail in P375^[30]. The temperature of the steel for this calculation should be based on the value of critical temperature obtained from Table 5.2. Table 5.2 has been calculated on the basis of a uniform temperature for the steel section. There is no limitation on the depth of the section that may be designed using the temperatures from Table 5.2, and the temperatures are appropriate for all values of shear connection. For beams designed to BS 5950-8, the use of the limiting temperature method is recommended.

Beams with web openings present a particular problem as far as the specification of fire protection is concerned, as the critical mode of failure may

be related to buckling of the web posts between the openings rather than global bending at the point of maximum applied moment. The performance of the fire protection material has also been found to influence the critical temperature. The critical temperatures given in Table 5.2 should not be applied to beams with web openings. Further guidance on fire protection of cellular beams is given in RT1187^[54].

Table 5.2 *Critical temperatures for composite downstand beams*

Description of member	Critical Temperature (°C) for a load level η_{fl} of:						
	0.7	0.6	0.5	0.4	0.3	0.2	0.1
Unprotected or protected composite members in bending supporting concrete slabs or composite slabs	535	567	600	641	680	738	838

When the ribs of the profiled steel decking run across the steel beams, voids are created between the decking and the top flange of the steel (see Figure 5.4). Although additional heat enters into the steel beam via these voids, BS EN1994-1-2 recommends that the voids are ignored if at least 85% of the surface of the top flange is in contact with the slab. This means that for re-entrant decks the voids do not need to be filled. However, for trapezoidal decks the voids must be filled - or the effect of the voids on the beam temperature must be considered when determining the critical temperature of the section. This is beyond the scope of the simple thermal model given in BS EN1994-1-2. Therefore, if the voids are to be unfilled, the temperature of the beam must be determined from tests or advanced analysis.

Fire tests in accordance with BS 476^[55] have shown the effects of unfilled voids on structural performance^[56]. As UK Building Regulations still recognise the BS 476 test methods, this guidance may still be used in the UK - although this situation may change in the future. Guidance in accordance with P109^[56] is given in Table 5.3 to identify when special measures must be taken because of these voids, and what they should be. In some cases it may be necessary to increase the thickness of fire protection to compensate for the adverse effect of the voids, or they may be filled.

It should nevertheless be remembered that, for all beams forming part of a fire compartment, the voids should always be filled to avoid affecting the integrity of the compartment wall.

Where the voids have to be filled, it is not necessary to use the same material as that used to protect the beam; any non-combustible material will suffice.

For beams with decking orientated parallel to them, the edges of the top flange must be protected; when board protection is used, the boards should be taken past the edge of the flange to abut the underside of the decking.

It is not always necessary to fire protect the voids between the steel flange and decking. Specifying such protection unnecessarily will lead to increased costs.

Table 5.3 Recommendations for fire protection of voids between profiled steel decking and steel beams in composite floor construction

Trapezoidal deck 				
Beam Type	Fire Protection on Beam	Fire Resistance (minutes)		
		Up to 60	90	Over 90
Composite	Insulating sprays and boards (assessed at 550°C)	No increase in thickness	Increase thickness by 10 % or assess thickness using A/V increased by 15%*	Fill voids
	Intumescent coatings (assessed at 620°C)	Increase thickness by 20% or assess thickness using A/V increased by 30%*	Increase thickness by 30% or assess thickness using A/V increased by 50%	Fill voids
Non-composite	All types	Fill voids		

Dovetail deck 				
Beam Type	Fire Protection on Beam	Fire Resistance (minutes)		
		Up to 60	90	Over 90
Any	All types	Voids may be left unfilled for all periods of fire resistance		

* The least onerous option may be used (A/V = heated surface area per unit volume of the steel section)

5.3 Shear connection

The longitudinal shear connection between the steel section and the concrete is provided by shear connectors, which normally take the form of studs welded to the top of the steel section. All connectors should be capable of resisting uplift forces caused by the tendency for the slab to separate from the beam as it bends. In the case of shear studs this is achieved by the head of the stud.

Although shear connectors ensure adequate fixing of the decking to the beam, they are not needed simply to achieve this. They should only be used when it is desired to achieve composite action between the slab and the steel beam, or to tie the slab at edge beams when the floor acts as a diaphragm.

5.3.1 Connectors

The most common type of shear connector used in composite beams for buildings is a 19 mm diameter by either 100 mm or 125 mm long welded stud. For thru-deck welding (see below), this is the only stud diameter that can be used practically, because it is the only one for which suitable ferules are available. Although other heights are available, they are not so easy to obtain.

There are a number of other forms of shear connector available, such as angles welded to the top flange. However, most lack a practical application in composite beams, with the exception of shot-fired connectors. These should be considered for smaller projects, those where beams need to be galvanized or top

flanges painted for reasons of durability, or indeed any project where the provision of power for stud welding is a problem. They may be particularly appropriate for refurbishment projects, where there is either limited access or no earthing facility. The most common shot-fired shear connector is that produced by Hilti, which is available in heights of 95 mm to 140 mm. It should be noted that a shot-fired connector has less resistance than a welded stud. Design guidance and design values of the shear resistance should be obtained from the supplier.

It should be noted that a shot-fired connector has less resistance than a welded stud. Design guidance should be obtained from the supplier.

Resistance

Design resistances of shear studs are given in BS EN 1994-1-1 and BS 5950-3, based on standard push-out tests on samples with ‘standard’ fabric reinforcement. However, tests have also been carried out on specimens with fibre reinforcement, and these results show they perform at least as well as those with fabric reinforcement. The design resistance is a function of the:

- shape of the decking profile
- size, strength and number of connectors per decking trough
- concrete properties
- the sheet thickness (according to BS EN 1994-1-1)

In BS EN 1994-1-1, the resistance of a stud in a solid slab is calculated directly from formulae which include terms for the concrete strength and modulus. The concrete modulus can be found in BS EN 1992-1-1^[24], where the value for normal concrete (E_{cm}) is given in Table 3.1, and the value for lightweight aggregate concrete (E_{lcm}) is given in Table 11.3.1. The presence of shallow cracking above a beam does not necessitate a reduction in the design resistance of the shear connectors, because of the presence of the transverse reinforcement or steel fabric reinforcement.

In BS 5950-3, the design resistance of a stud in a solid slab in normal weight concrete is given in Table 5, according to concrete strength and stud dimensions. These values are reduced by 10% when lightweight concrete is used.

The reason why the efficiency of the shear connectors is reduced when the decking is orientated with the ribs transverse to the beam is because the force transferred through the shear connector into the slab relies on a small localised area of concrete immediately in front of the stud. For this orientation of the decking, this area of concrete is limited in size by the presence of the profile, as shown in Figure 5.5. Reduction formulae are given in BS EN 1994-1-1 and BS 5950-3 to allow for this by considering the relative geometry of the stud and the decking rib.

As well as the shape and thickness of the decking, the position of the stud in the trough is important; tests have shown that the integrity of this local area of concrete can break down if the stud is positioned close to the decking. The formulae given in BS EN 1994-1-1 and BS 5950-3 assume that studs are located centrally in the troughs, or are alternated between the ‘favourable’ and ‘unfavourable’ side of the trough. Recommended practice is to place the studs in

the ‘favourable’ side (see Figure 5.5). This means that, for single studs on simply supported beams with symmetric loading, the position of the stud in a trough with a central stiffener must change at mid-span.

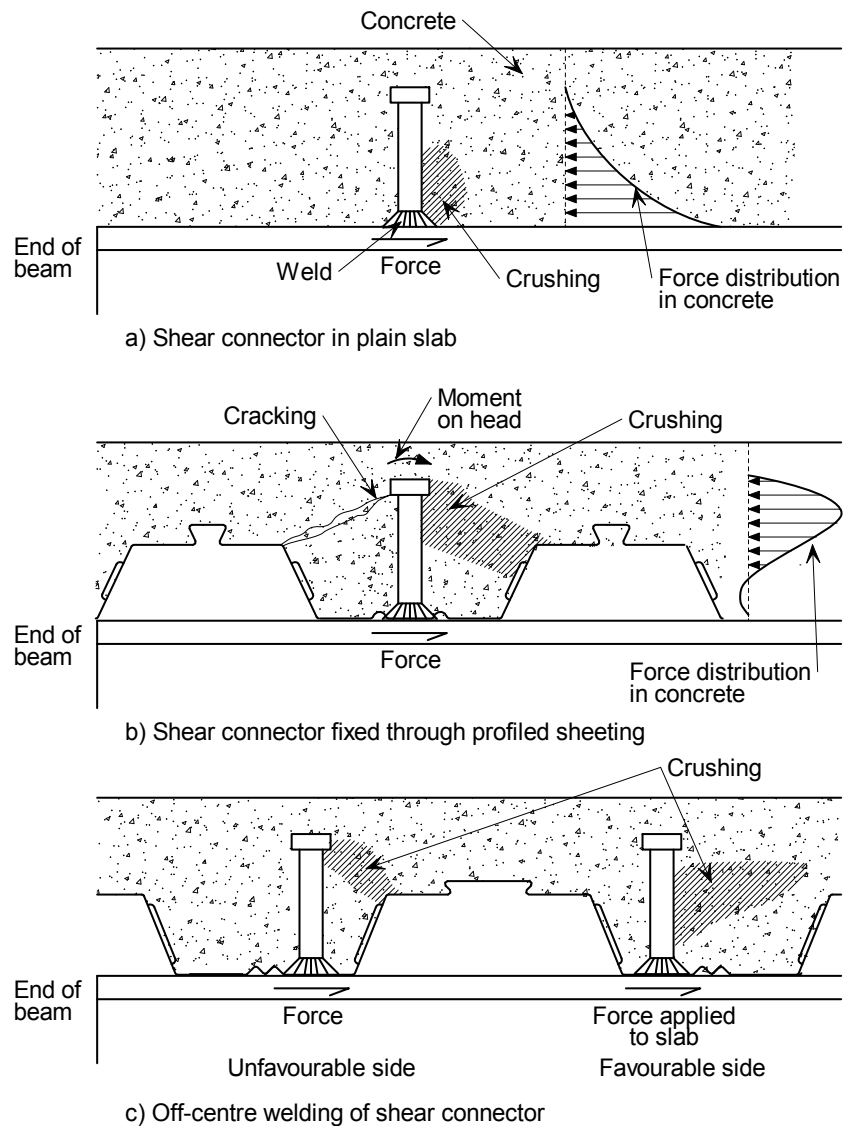

Figure 5.5 *Shear connector forces in composite slabs*

The number of studs placed transversely (across the width of the beam) in each trough also affects their resistance. A reduction factor should be applied to the design resistance when two studs are present. Note that the design resistances given in BS EN 1994-1-1 explicitly do not cover more than two studs per trough. For further information, reference should be made to the Designer’s guide to BS EN 1994-1-1^[26] and the *Commentary on BS 5950: Part 3: Section 3.1 Composite beams*^[46].

Attachment of studs

‘Thru-deck’ welding is generally used, particularly in the UK, to attach the shear studs to the steel beams. This process welds the stud, decking and steel section effectively together in a single operation. A typical run of thru-deck welded shear studs is shown in Figure 5.7. The Structural Designer should recognise the following practical limitations before specifying thru-deck welding:

- The galvanized steel decking should not exceed 1.25 mm thick, and the total galvanizing thickness should not exceed 0.04 mm.
- The thickness of the top flange of the steel section must not be less than 0.4 times the stud diameter (i.e. 7.6 mm for a 19 mm stud) to prevent localised bending of the flange at ultimate loading.
- Small numbers of studs are uneconomic because of the amount and expense of the equipment needed.
- A clear height above a beam of at least 450 mm is necessary to carry out the process of stud welding, i.e. to give room for the operative and equipment. (A typical example of where a problem can occur is when there is a change in the floor level, as shown in Figure 5.6.) In these situations it may also prove difficult to fix the slab edge trim.
- The need to keep the top of the beam flange free of paint is generally not a problem (in an internal environment having an exposed, unprotected top of flange in the 'voids' is acceptable). Thru-deck welding may however blister any paint applied, and required, on the underside of the flange. Remedial measures may be required for aesthetic, if not corrosion protection, reasons. An intumescent coating on the underside of the flange might also be damaged, but would not normally need remedial work other than for aesthetic reasons.
- A minimum flange width is needed to provide sufficient bearing for the decking on both sides, end distance from the stud to the sheet when anchorage from the stud is required (for decking design and to enable the decking to be included as transverse reinforcement and shear reinforcement), and transverse distance between studs. Consequently, when the decking is perpendicular to the beam, flange widths less than 125 mm are not recommended (see below for advice when pre-welded studs are used).

Further limitations, related to site practice, are discussed in Section 6.5.

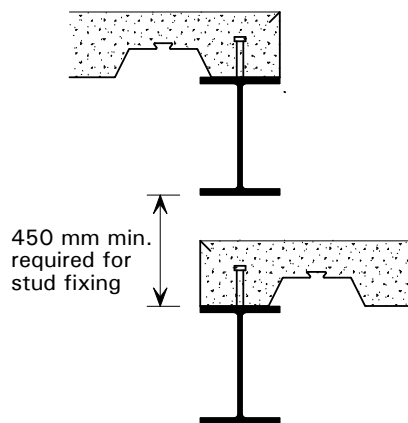

Figure 5.6 *Minimum height clearance for stud welding*

Thru-deck welding is significantly more economical than the alternative of pre-welding the studs to the steel beams in the factory, although it is not possible when the beam has to be galvanized. Problems associated with using pre-welded studs include:

- Erection becomes more hazardous and therefore slower.
- Decking has to be laid in single spans between the lines of studs, which requires beams with a sufficient flange width (≥ 133 mm) to provide the

minimum safe bearing for the decking on each side of the beam, and the decking is less efficient as a single-spanning member.

- Alignment of the troughs in decking perpendicular to the beam with pre-welded studs can be difficult. The flange width should be specified so that, should they not align, at least 50 mm concrete encasement is provided beyond the transverse spacing of the studs to the edges of the decking. The stud resistance may be reduced when studs do not align with the troughs, and it should be calculated using the reduction factor for ribs parallel to the beam using the width of encasement provided, rather than the reduction factor for ribs perpendicular to beam.

Holes may be cut in the decking to avoid these problems, but this leads to other complications trying to align the studs and holes. Decking placement will become more hazardous because of the need to slot the studs through the holes, and so this method is not recommended.

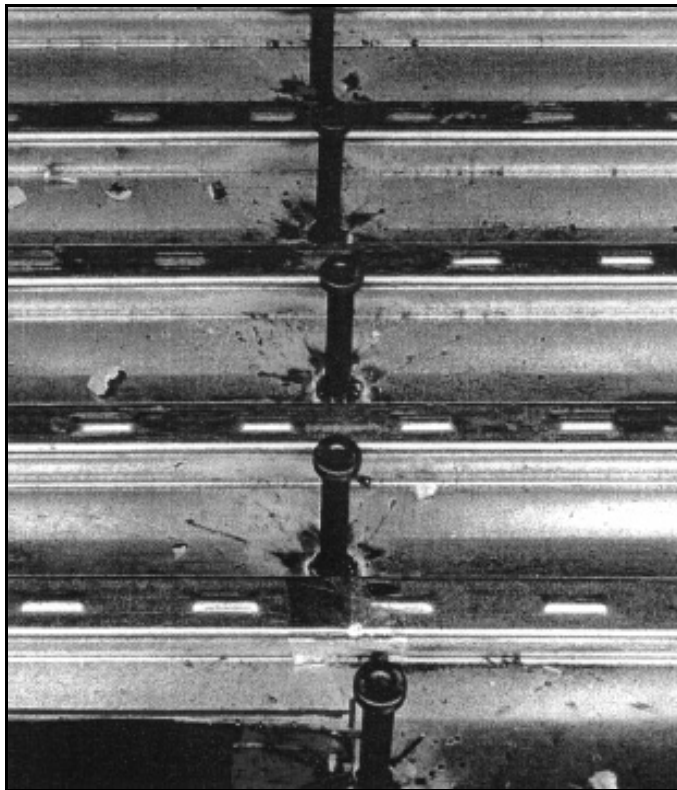

Figure 5.7 *A typical run of stud shear connectors*

Detailing rules

The following detailing rules apply to the positioning of stud shear connectors, and are illustrated in see Figure 5.9:

- BS EN 1994-1-1 requires that nominal height (before welding) of the shear studs should be at least $2d$ (where d is the stud diameter) above the top of the decking. The corresponding requirement in BS 5950-3 is 35 mm. (Note that the ‘top of the decking’ refers to the height of the shoulder, i.e. excluding any small stiffening ribs in the crest of the decking.) Studs that are longer than is necessary to meet these requirements will not have a greater resistance.
- To avoid damaging the decking, the studs should be located along pre-determined lines marked on it.

- The distance between the edge of the shear connector and the edge of the steel flange should not be less than 20 mm.
- The minimum longitudinal spacing of the studs should be $5d$. BS EN 1994-1-1 states that the maximum spacing should not exceed the lesser of 800 mm and six times the slab depth. The limit given in BS 5950-3 is 450 mm, and this latter value is recommended in the light of recent test evidence^[57]. It should be noted that studs are often required at larger spacings than these on non-composite beams for other purposes, such as restraint of the beam.
- The transverse stud spacing should not be less than $2.5d$ in solid slabs and $4d$ in other cases.
- Studs should normally be placed uniformly along the length of the beam; one (or a pair) in every trough of the decking, or one in alternate troughs. Any additional studs noted on the drawing that cannot be placed in equal numbers in all the troughs should be positioned symmetrically about the mid-span of the beam, working from the supports inward (assuming uniformly distributed loading).
- When the decking has a central stiffener in the trough (which makes it impossible to attach the stud centrally), the studs should be attached on the favourable side of the trough. For symmetrically loaded beams, this will involve a changeover of position of the stud at mid-span.
- At discontinuities in the decking, the studs should anchor both sheets. The minimum distance from the centre of the stud to the edge of each sheet should be 30 mm. Because of this, beams with flange widths less than 125 mm are not recommended – see notes on attachment of studs, above. [Note that studs should never be welded through two layers of decking. At joints, it is recommended the decking should be butted, and when studs are in single lines they should be welded alternately on one sheet then the other, and when in pairs they can be welded one on each.]
- Studs attached to edge beams should be placed no closer than $6d$ (from the stud centre-line) to the slab edge, as shown in Figure 5.8. Where the slab edge is less than 300 mm from the line of the studs, ‘U’ bars should be specified around the studs in accordance with BS EN 1994-1-1 (or BS 5950-3) to prevent bursting of the concrete near the slab edge.

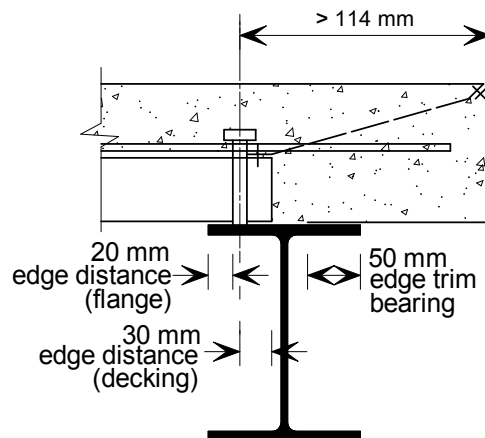
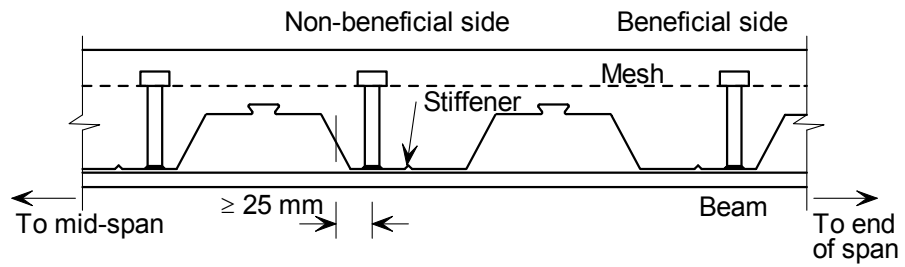
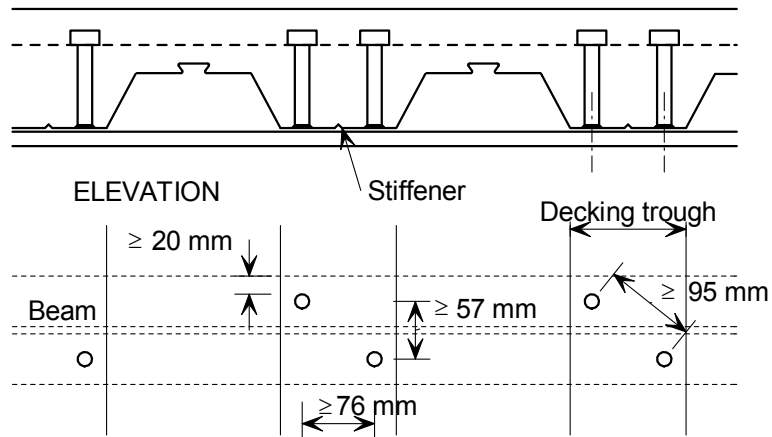

Figure 5.8 Shear connector detailing at an edge (for 19 mm diameter studs)



a) Single shear connector per trough in staggered pattern



b) Pairs of shear connectors per trough in staggered pattern

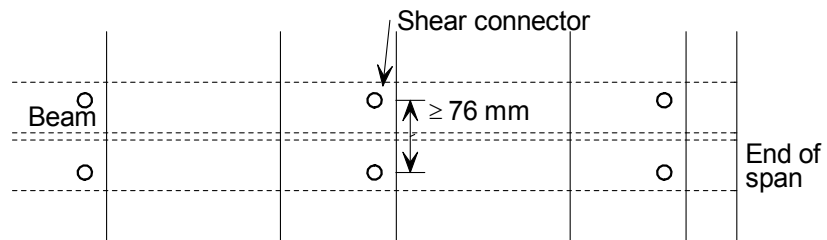

c) Correct positioning of pairs of studs not in a staggered pattern

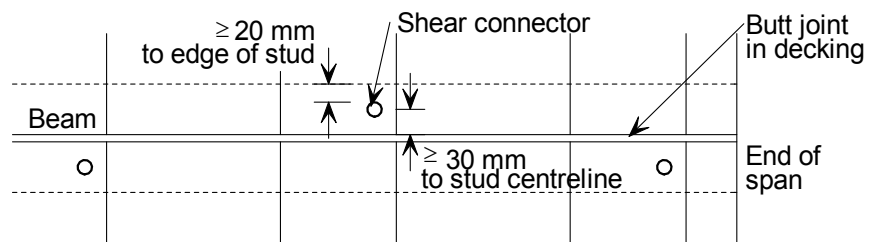

d) Butt joint in decking (correct positioning of single stud per trough)

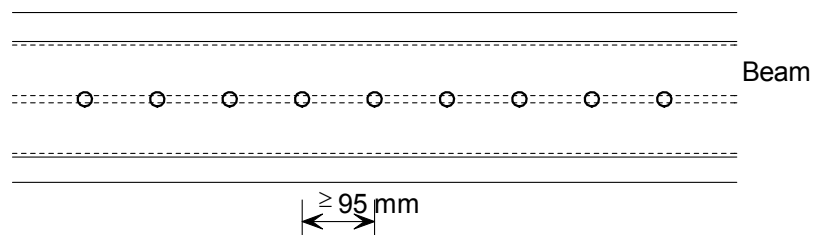

e) Shear connectors on decking laid parallel to beam

Figure 5.9 Detailing of shear connectors (19 mm diameter) welded through decking

5.3.2 Longitudinal shear

Composite beams may be designed plastically if the shear connectors are sufficiently ductile. This enables a plastic shear connection resistance to be assumed, whereby the maximum resistance in each connector is assumed to occur simultaneously down the length of the beam. BS EN 1994-1-1 states that 19 mm diameter studs with a ‘length as welded’ greater than 76 mm may be assumed to satisfy this requirement. The total longitudinal shear force that can be transferred across the steel-concrete interface is the sum of the resistances of the shear connectors positioned within the length between a support and the point of zero bending moment. Where the loading is asymmetric, the lesser of the resistances totalled either side of the point of zero bending should be used.

Transverse reinforcement

The longitudinal shear resistance of the concrete slab must be checked to ensure that the force from the shear connectors can be transferred into the slab without splitting the concrete. This requires the provision of transverse reinforcement (perpendicular to the beam centre-line). It is usually found that fabric or fibre reinforcement is sufficient for the design of secondary beams, where the decking ribs run perpendicular to the beam (as shown in Figure 5.10(a)). For beams where the ribs run parallel to the beam (Figure 5.10(b)) additional bar reinforcement is likely to be required. Potential shear planes through the slab lie on either side of the shear connectors (Figure 5.10). However, plane b-b need not be checked for composite slabs with decking because characteristic stud resistances are determined from tests which allow for this type of failure. The shear resistance per unit length of shear plane along the beam is a function of the concrete strength and the amount of reinforcement provided.

For edge beams, ‘U’ bars should be positioned as low as possible but with sufficient bottom cover for the aggregate to flow (BS 5950-3 states that the bars should be placed at least 15 mm below the head of the stud, although there is no such requirement in BS EN 1994-1-1).

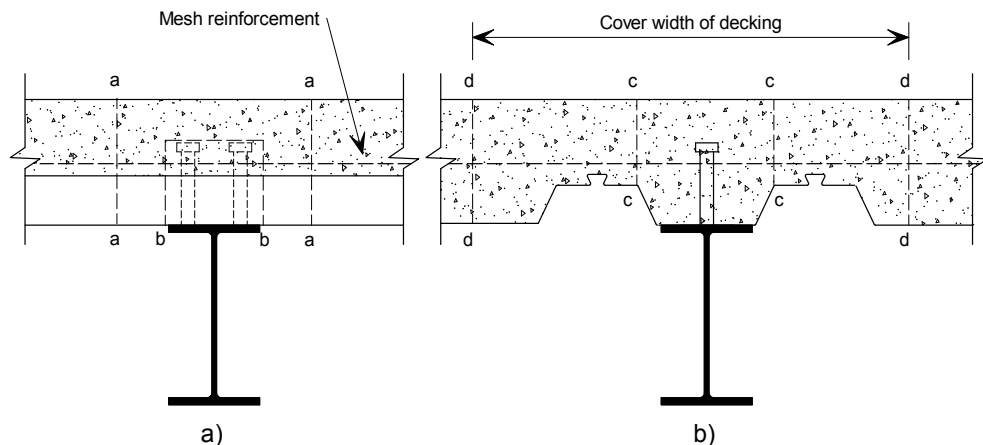

Figure 5.10 *Potential failure planes through the slab in longitudinal shear (a) Decking perpendicular to beam (b) Decking parallel to beam*

The decking may also act as part of the transverse reinforcement to contribute to the longitudinal shear resistance. The full resistance of the decking can be used when it is placed transverse to the beams and is continuous. In situations where the decking is discontinuous, the anchorage force that can be developed by the shear connectors limits this action, but the decking contribution may be

included, provided that there is sufficient end distance of the decking beyond the centre line of the studs. Guidance on the anchorage resistance is given in BS EN 1994-1-1 (clause 9.7.4(3)) and in BS 5950-4 (clause 6.4.3), but minimum values are quoted as 1.65 times stud diameter in the former and 1.7 times stud diameter in the latter.

The contribution of the decking should always be neglected where it is not properly anchored at discontinuities, or where the decking ribs run parallel to the beam. In theory, when the decking is parallel to the beam and properly anchored, some contribution to the longitudinal shear resistance could be included. However, including this contribution is not recommended because the decking resistance is affected by the (unpredictable) presence of laps on site; this approach is consistent with BS EN 1994-1-1. Studs fixed in a single line at a butt joint in the decking do not provide sufficient anchorage for the decking to contribute to the transverse reinforcement. Further guidance on transverse reinforcement can be found in AD 192^[58] and AD 266^[59].

Transverse reinforcement is always needed to ensure adequate performance of the shear connection. Fabric may be sufficient, but a check is always necessary, particularly for primary beams. Fabric is preferred because it minimises the need for steel fixers to work in a bent position.

The contribution of the decking to the transverse reinforcement can only be included if it is properly anchored, and this depends on a number of factors - continuity of the decking, decking rib orientation, and laps in the decking. The contribution of the decking should always be neglected where the ribs run parallel to the beam.

Bending resistance envelope

The bending resistance of a composite beam depends on the shear transfer between the beam and the slab. Consequently, the resistance increases away from the supports; the resistance at a given point is a function of the resistance moment of the bare steel beam and the number of connectors between that point and the nearest support.

For a beam subject to uniformly distributed load, the maximum design moment is at mid span. It is only necessary for the Structural Designer to check the moment resistance at this point, and determine the total number of connectors needed to transfer the load into the slab (see Section 5.2.1 and Figure 5.3); these connectors may be evenly distributed between the support and mid-span.

For beams subject to point loads, it is necessary to check the resistance moment at intermediate points, not just the point of maximum design moment. For example, Figure 5.11 shows a beam with four point loads, the applied bending moment diagram, and a resistance moment that is just sufficient at each of the four load positions. To achieve the required resistance at the intermediate point 'A', the number of connectors between that point and the nearest support must enable sufficient force to be transferred to the slab to achieve the required resistance M_A . With a heavy point load close to the support, it may not be possible to accommodate the required number of studs over that short length.

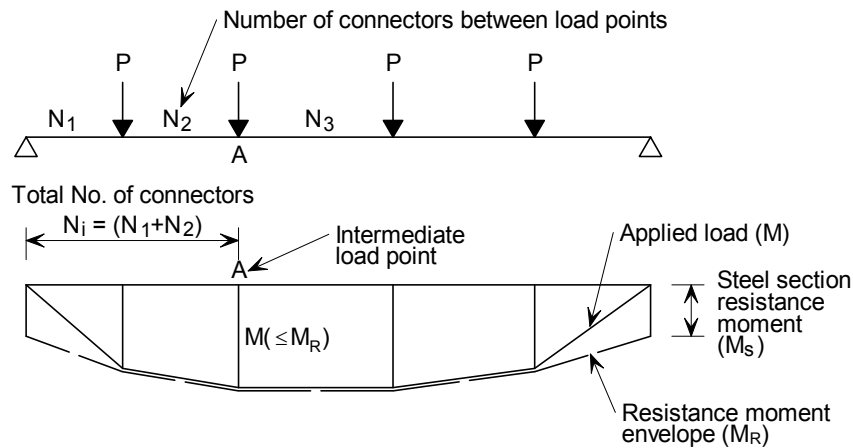

Figure 5.11 *Shear connector distribution for beams subject to point loading*

5.3.3 Degree of shear connection

The maximum longitudinal shear force that is required to be transferred from the steel to the concrete is the lesser of the compressive force to cause concrete crushing, and the force that would cause yielding of the steel section in tension. If sufficient shear connectors can be provided to transfer this force, the full plastic resistance moment of the composite section can be achieved. This is known as providing ‘full shear connection’ (sometimes referred to as full interaction).

‘Partial shear connection’ refers to situation in which fewer shear connectors are provided. In this case, the stress block method used for calculating the resistance moment (see Section 5.2.1) must be modified to take into account the reduced longitudinal force that can be transferred. The use of partial interaction often results in improved economy, especially where the number of shear connectors is limited by the spacing of the ribs in the decking.

Deformation of the shear connectors allows slip between the concrete and the steel section. This slip is zero at the point of maximum bending moment (often at mid-span) and increases towards the supports; the longer the beam span, the greater the slip at the supports. For partial shear connection, because there are fewer shear connectors, there will be more slip for a given load than with full shear connection. To avoid any adverse effects arising from excessive slip, a minimum limit to the degree of shear connection is specified in BS EN 1994-1-1 and BS 5950-3, although the rules differ between them slightly.

Further guidance on the degree of shear connection can be found in AD 266^[59].

5.4 Further reading

The references given below relate particularly to beam design - see Section 4.5 for additional design guidance related more to slabs. (For information on authors and publishers, see Section 8, References.)

Interfaces: Design of steel framed buildings for service integration (P166)^[35]

This design guide outlines the various services that have to be integrated into the floor zone of a building and illustrates how this may be achieved with several different structural steel floor framing systems, many of which incorporate composite floors.

Designer's guide to BS EN 1994-1-1^[29]

This guide provides the detailed background to the clauses to Eurocode 4. It includes many worked examples that show the application of the individual clauses. It is a standard reference for designers of composite beams to EC4.

Commentary on BS 5950: Part 3: Section 3.1 Composite beams (P078)^[46]

This is a comprehensive guide that provides the background to the clauses in the BS 5950-3. It discusses the relevant research, and includes a worked example of the design of a composite beam. It is an essential reference for designers of composite beams in the UK.

Design of beams with large web openings for services (P355)^[50]

This guide provides a design method for both composite and non-composite beams with web openings. A model for the complex force distribution around an opening is explained, from which a simplified method for stiffened and un-stiffened openings is derived. Guidance on the positioning and size of openings is included.

P354: Design of floors for vibration: A new approach (P354)^[51]

This guide examines the theoretical aspects of vibrations in buildings caused by people walking. It shows how floors may be analysed for their dynamic sensitivity, and suggests acceptance criteria for the floor response.

Fire protection for structural steel in buildings (4th Edition)^[60]

This publication explains the basic aspects of fire protection and fire protection appraisal procedures. It gives application details for most of the products available, and protection thickness required for different beam and column exposure conditions. This is the standard design reference for fire protection of structural steel.

Structural fire design: Off-site applied thin film intumescent coatings (2nd edition) (P160)^[53]

This publication describes the design and specification issues relating to off-site applied thin film intumescent coatings. An example of a calculation for the determination of the coating thickness for a steel member is presented. A 'model' Specification is also included.

Managing construction for health and safety - Construction (Design and Management) Regulations, 2007. Approved Code of Practice L144 (ACoP)^[4]

This document contains the Regulations themselves, together with an explanatory commentary for each requirement. It is an essential source document.

P178: Design for construction (P178)^[61]

This guide highlights the effects of basic design decisions on the overall buildability and cost of a building. It is aimed at engineers primarily, but has a relevance to all those having a design input. It includes a section on the 1994 CDM Regulations.

Advisory Desk

The following 'Advisory Desk' items, published by the SCI in New Steel Construction and on the SCI Steelbiz web site www.steelbiz.org, provide further information relevant to this Section:

AD 174, *Shear connection along composite edge beams*^[62]. This note outlines a method for checking the bending resistance of composite edge beams in existing

buildings where the shear connectors have not been properly fixed, or the transverse reinforcement has been omitted.

AD 175, *Diaphragm action of steel decking during construction*^[7]. A method is given in this note for checking the adequacy of the decking to stabilise the structure by providing diaphragm action. Fixing requirements are given.

AD 192, *Transverse reinforcement in composite T-beams*^[58]. A detailed description of the principles of longitudinal shear, and the role of transverse reinforcement, is given in this note. The background to the relevant clauses in BS 5950-3 is explained.

AD 266, *Shear connection in composite beams*^[59]. This note discusses the basis for effective breadth rules, the minimum degree of shear connection rules and transverse reinforcement calculations.

6 CONSTRUCTION PRACTICE - CONCRETE

This Section provides information concerning good practice in relation to the site activities associated with the procurement, placement and finishing of in-situ concrete. It is aimed at all personnel involved in the site activities. Guidance on concrete mix design is included, but guidance is not given on access requirements for concrete mixers, checking of concrete delivery notes etc. These issues are considered to be general site practice, and not appropriate for inclusion in a guide on composite construction.

6.1 Concrete supply

Concrete supply is normally the responsibility of the Main Contractor, who should make sure that it is specified, supplied and assessed in accordance with BS 8500-1^[17] to meet the strength grade specified by the Structural Designer. Basic details for some typical concrete mixes are given in Table 6.1.

Table 6.1 *Concrete specifications (extracted from BS 8500)*

Aggregate Type	Normal weight					Lightweight		
	C25/30	C28/35	C32/40	C35/45	C40/50	LC25/28	LC28/31	LC32/35
Maximum water cement ratio	0.65	0.60	0.55	0.50	0.45	0.65	0.60	0.55
Minimum cement content (kg/m ³)	260	280	300	320	340	260	280	300

Notes:

1. BS 8500-1 does not give universal relationships between strength class and water cement ratio and minimum cement content. The relationships depends upon the exposure class and cement types used. The relationships shown in table 6.1 are those given in BS 8500-1 for XC exposure conditions. Other strength class/water cement ratio/cement content relationships are listed in BS 8500-1 for other exposure conditions.
2. The minimum cement contents listed are for 20 mm aggregate. Generally minimum cement contents would need to be increased by 20 kg/m³ for 14 mm aggregate and 40 kg/m³ for 10 mm aggregate

To ensure the quality control of the concrete mix, it should be obtained from a plant providing concrete in accordance with an approved quality assurance scheme.

Aggregate types and size

Most composite slabs are constructed with a normal aggregate, but lightweight aggregate is available.

When normal concrete is specified, the maximum size of the aggregate needs to be limited to ensure that the concrete may be placed easily into the decking ribs and between the reinforcing bars.

The nominal dimension of the largest aggregate, which has an angular nature, should not exceed the smallest of the following limits (see Figure 6.1).

- 40% of the concrete cover above the ribs.
- The average width of the decking ribs (trapezoidal decking).

- One third of the minimum rib width (dovetail decking).

It is recommended that 20 mm aggregate is used whenever possible. When smaller aggregates are used, the required cement content will increase, and the shrinkage performance of the concrete will be adversely affected.

With lightweight concrete, aggregate size is not a problem because of the small rounded nature of the pellets.

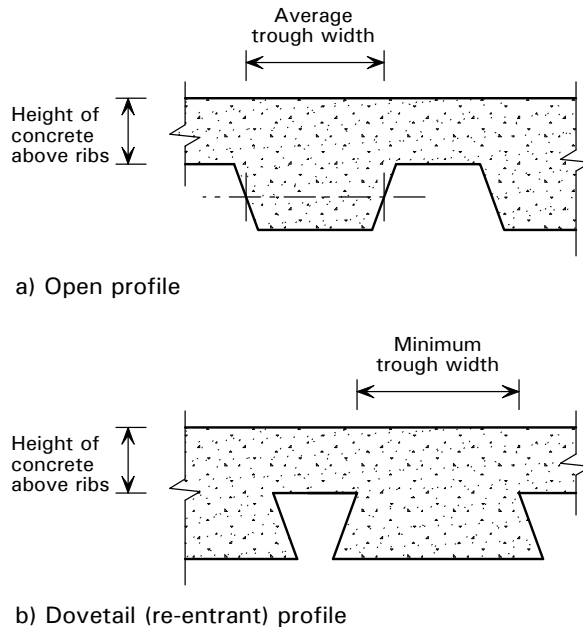

Figure 6.1 *Nominal cross-sectional dimensions used to determine maximum concrete aggregate size*

Consistence

To ensure that the concrete is sufficiently workable to allow it to be pumped with the correct flow, and to achieve adequate compaction around the reinforcement, in the troughs of the decking and around the steel beams in slim floors, a minimum consistence class of S3 should be specified in line with BS 8500-1.

Concrete mixes with low consistence should not be used as this can lead more readily to heaping of the concrete and overloading of the steel deck.

6.2 Placing concrete

6.2.1 Preparation

Prior to beginning work on the decking, guard rails should be in position at all perimeters, internal edges and voids. The positions of any props (and back props) should be checked against the details shown on the decking layout drawings to ensure that the required support has been provided.

Cleaning the decking

The surface of the decking should be reasonably free of dirt, oil, etc. prior to concreting. The slight surface grease that is present on the decking when it is delivered to site does not affect the interaction between the concrete and steel,

and therefore need not be removed. Though recommended, it is not essential to clean out all the broken ceramic ferrules from stud welding.

Construction joints

Typical pour sizes are up to 1000 m²/day, although there is no technical limitation to the area that may be concreted. Where the limits of the pour do not coincide with permanent slab edges, construction joints (day joints) are used to define the extent of the pour.

Where possible, the construction joints should be located close to butt joints in the decking. For conventional composite beams, it is preferable to create the joint to one side of the line of the shear connectors, to ensure sound concrete around the studs. This does not affect the resistance of the shear connectors. If the construction joint cannot be made near a butt joint, it is suggested that no more than one-third of the decking span from a butt joint should be left unpoured, as shown in Figure 6.2. Concreting should not be stopped within a sheet length with more than this left unpoured because excessive deflections might occur when the loads on a continuous decking sheet are not balanced either side of the intermediate support beam.

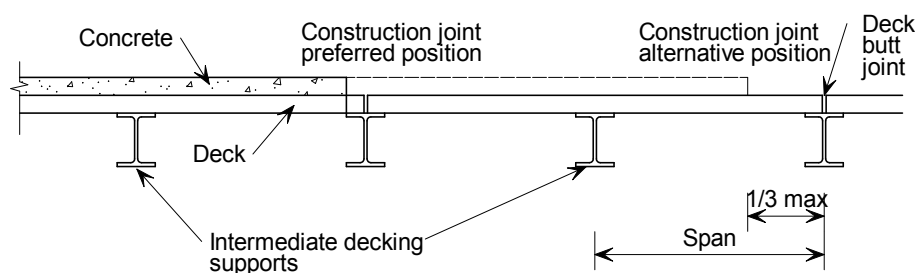

Figure 6.2 Recommended positions for construction joints in the concrete slab

Stop ends, usually in the form of timber or plastic inserts, are used to create the construction joints. As with all the joints and ends of the decking, they should be checked for potential grout loss.

A construction joint will form a discontinuity in the slab, so it is important that continuity reinforcement is provided across the joint. When fibre reinforcement is used, continuity reinforcement in the form of conventional reinforcing bars or a strip of steel fabric will be required at construction joints. The decking supplier should be consulted regarding the continuity reinforcement required in fibre reinforced slabs. The occurrence of cracking in the concrete adjacent to day joints is normal, and does not affect the structural performance. If the size of the crack at the construction joint is important, e.g. when brittle finishes are being used, the reinforcement should be sized to control the crack width by the structural designer. Alternatively, there are commercial systems for decoupling brittle finishes from the underlying composite concrete slab, and guidance on their use should be sought from the supplier.

Bar and fabric (mesh) reinforcement

All bar/fabric reinforcement should be properly supported so that it does not become displaced during concreting. Plastic stools, loops or preformed fabric may be used as 'chairs', but not plastic channels, which can induce cracking. Chairs should be robust, because operatives will need to use the floor as a working platform for themselves and their equipment. In particular, the handling

and movement of concrete-filled pipes during pumping can cause significant local impacts on the fabric reinforcement. Although a slight depression (up to 15 mm) of the fabric may occur during concreting, the performance of the slab is not affected significantly by this. An example of a floor with the reinforcement in place and ready for casting is shown in Figure 6.3.



Figure 6.3 *Decking and fabric reinforcement – ready for casting the concrete*

The reinforcement that has been fixed should be checked against the slab reinforcement drawing. Particular attention should be given to checking any additional bar reinforcement, such as may be needed around openings, across composite beams and U-bars for composite edge beams.

Fibre reinforcement

When steel or polymer fibres are used, they are added to the concrete mix at the batching plant, or directly in to the mixer on site. Fibre reinforced concrete can be pumped to elevated floors, as shown in Figure 6.4. When using a fibre reinforcement solution, it is still general practice to use U-bars on composite edge beams, bar reinforcement around openings in the slab, and fabric or bar reinforcement at construction joints, or where the composite slab cantilevers beyond a support. When preparing for concreting, the site team should ensure that any such bars/fabric are present.

Grout loss

The decking joints should be closely butted and exposed ends should be ‘stopped’ with proprietary filler pieces to avoid grout loss. Gaps greater than 5 mm should be sealed, but gaps smaller than this do not need any special provision normally. Small gaps may be spray-filled with expanding polyurethane foam.



Figure 6.4 *Pumping of fibre-reinforced concrete*

Tamping rails

Tamping rails should be placed close to the beam centre-lines, to avoid excessive deflection during concreting. The level of the concrete top surface will then tend to reflect the deflected shape of the beams.

Mass flood technique

Where a ‘mass flood’ technique of casting (whereby the concrete is poured and the whole floor levelled to a fixed datum) is used, considerably more concrete will be needed and thicker slabs will result from deflections of the steelwork and decking. Levelling to a fixed datum should not be adopted without first confirming with the Structural Designer that the extra weight of concrete ‘ponding’ has been allowed for in the design.

6.2.2 Placement

The concrete should be well compacted, particularly near and around any shear connectors. This can be done using a vibrating beam, which will require adequate supports at both ends, or by an immersion poker vibrator. Hand tamping is not recommended as a way of compacting the concrete.

Concrete can be placed when the air temperature is 5°C or above. In cold weather, it may be necessary to make provision to maintain this temperature during at least part of the curing period (see below).

Concrete pumping

Pumping has become the normal way of placing concrete, and can be adopted for both normal and lightweight aggregate mixes. Flow rates in the order of 0.5 to 1 m³ of concrete per minute can be achieved, although, clearly, the longer the pump lines and the higher the concrete is to be pumped, the slower the operation. A pump can normally ‘lift’ the concrete up to 30 m. Secondary pumps, placed at intermediate levels, may be necessary for higher lifts.

Pump lines are normally 150 mm in diameter and are assembled in segments. Because the force exerted at bends can be significant, straight line pumping is preferred. The lines should be supported on timber blocks at intervals of 2 to 3 m. Resetting of pump lines is required at frequent intervals as the pour progresses. This means that the outlet pipe should be moved frequently and carefully so that concrete heaping is minimised. A minimum of two operatives are necessary for this operation, one to hold and manoeuvre the outlet pipe, the other to shovel away excess concrete. No more than 4 workmen should be present around the pipe outlet during pumping, because of the potential for overloading the decking. The concrete should not be dropped from the outlet pipe onto the decking from a height of more than about 1 m.

Any low quality concrete (the first part of each lorry load, or after flushing out pipeline blockages) should be discarded.

Skip and barrow

Ideally, concrete should always be placed by pump, but there will be occasions when small areas need to be concreted where placing by pump is not practical. Considerable care is needed if a skip and barrows are to be used, to ensure the decking is not overloaded. It would be preferable to discharge concrete into barrows on previously constructed areas, to avoid concrete being discharged directly from a skip onto decking. Placing concrete from a skip hung from a crane may be difficult because of obstructions from beams and decking at higher floor levels. However, despite being time consuming (progress rates rarely exceed 5 m³ per hour), it is sometimes efficient to use the skip and barrow technique for small infill bays.

Skips should have a means of controlling the rate of discharge, and should not be discharged from more than 0.5 metres above the decking or barrow. When discharging into a barrow, the barrow should be supported by thick (30 mm) boards covering a 2 m by 2 m area, or by a finished part of the slab. Either provision limits impact loads. Barrows should be run over thick boards placed on the fabric reinforcement, which should be supported locally.

Testing

The concrete should normally be tested in accordance with the requirements of BS EN 12350^[63]. At least two cubes will need to be taken from every 20 m³ delivered and batched, or two cubes per day if the quantity used that day is less than 20 m³. The cubes are crushed at 28 days, and the average of the two cubes strengths becomes the individual 28 day result for the batch sampled. Additional cubes may be taken for testing at 7 days, or other ages, for the determination of early strengths.

6.2.3 Finishing, curing and drying

The concrete surface finish is normally specified by the Structural Designer (Section 4.2.1). If power-floating is to be carried out, this should be done within 2-3 hours of casting. This allows time for the concrete to sufficiently harden.

Experience shows that there is a high risk that well trowelled surfaces will exhibit crazing^[64]. Crazing is the term used to describe an irregular polygonal pattern of fine interconnected cracks which often occur on power trowelled concrete surfaces. Crazing should not be considered a defect and it generally has no adverse effect on the performance of the floor surface.

Although concrete normally gains strength relatively quickly, it is necessary to keep temperatures above 5°C for at least 3 days after pouring. When concreting during the winter months, loss of heat, such as by radiation from the lower surface of the decking at night, can be significant. It may then be necessary to use space-heaters to maintain the temperature. Some heat is generated during setting, or 'hydration', of the concrete (this raises the temperature by 3 to 5°C, typically).

The moisture in the concrete should not be allowed to evaporate too early, otherwise the surface may lose its integrity, forming dust and possibly cracking, and it will not have a good abrasion resistance. The slab therefore needs to be 'cured' by covering the surface with polythene sheeting for 3 to 7 days, depending on the weather (this is particularly important in warm or windy weather). Alternatively, the concrete may be sprayed with a proprietary curing compound.

Because the concrete is only exposed on one surface of a composite floor, it can take longer than a traditional reinforced concrete slab to dry out. The preferred method of checking the moisture content of the slab is the insulated hygrometer method given in BS 8203^[65].

6.3 Loads on the slab during and after concreting

6.3.1 Loads during concreting

Loads during concreting arise mainly from the weight of the operatives, concrete, pump-lines and impact forces. Loads to be taken into account for design during concreting are specified in BS EN 1991-1-6 and in BS 5950-3, and are outlined in Section 4.1.2. The self weight of the finished slab (typically 2 to 3 kN/m²) and local loading (caused by normal localised heaping of the concrete) are included. This is usually not critical because adjacent areas of decking are unloaded, or only partially loaded.

The following list describes the loads that usually arise during concreting, and that will normally have been allowed for by the Structural Designer:

- A concrete gang consisting of 5 or 6 men (only 4 of whom are within 2 m of the pump outlet).
- Concrete that is poured from no higher than knee level above the decking (to avoid excessive impact loading).
- A 150 mm diameter pipeline full of concrete. [The weight of the line should be adequately spread across the decking by using suitable timbers to avoid local damage to the deck.]
- A cone of heaped concrete of approximately 0.2 m height and 1 m base. It will have been assumed that the pump line outlet will be moved frequently to avoid excessive heaping (or, if a skip is used, the discharge will be carefully controlled).

Additional concrete may be placed because of deflections of both the decking and the steel frame, particularly if the slab is finished to 'absolute' (datum) levels. The Structural Designer must be consulted to confirm whether the resultant increased loads have been allowed for in the design. Levelling the top of slab to achieve a uniform thickness, rather than a 'level' top surface is recommended and will avoid this problem.

6.3.2 Construction loads after concreting

Construction loads are often applied to the slab soon after concreting. Examples of commonly occurring loads are bags of fire protection, skips of debris, pallets of blocks and other equipment. If these loads are no more than 1.5 kN/m^2 (over a 3 m by 3 m area), the construction load used in the design of the decking, then the slab is clearly not overloaded (provided there is no additional, unforeseen load due to 'ponding'). For loads above this, the concrete strength will need to be relied upon. Props should not be removed, nor additional loads applied, until the concrete has reached 75% of its design strength, as indicated by 'control' concrete compression tests. If the slab is to be loaded before 28 days after concreting, its strength at the time of loading needs to be established (possibly by testing cubes or cylinders early), and an effective 'design strength' agreed with the Structural Designer.

The following list gives examples of typical construction loads. Items are assumed to be placed on pallets, which should always be positioned directly over the support beams:

- Concrete blocks: a 1 m high pallet of blocks applies a load up to 10 kN/m^2 .
- Bricks: a 1 m high pallet of bricks can exert a load of over 15 kN/m^2 .
- Bags of fire protection: a bag of fire protection material normally weighs 25 kg. A 1 m high pallet of bags can be equivalent to a load of 2.5 kN/m^2 .
- Bags of cement: bags of cement weigh 25 kg each. A standard pallet of these weighs 1,400 kg (12 kN/m^2).

The application of very heavy construction loads should always be referred to the Structural Designer. When considering the location of such loads, it is best to position them over the beams wherever possible. Examples of such loads are:

- Generators: welding generators can apply a load of 50 kN.
- Fork lift trucks: fork lift trucks can exert a load up to 100 kN, not including their live load. In general, vehicles with axle weights above 3 tonnes should be used only if the slab has been designed/checked specifically for that purpose.
- Crane counter weights: each counter weight is marked clearly with the value of its weight.
- Mobile access platforms: The potential loading imposed by any mobile access platforms used to install services, finishes, etc should be checked.

A procedure for checking the adequacy of the slab to support heavy point loads, such as the wheel loads from forklift trucks, is given in AD 150^[44].

Care is needed if a composite floor is to be used in situations where there could be frequent vehicle movements. Designing such floors just for uniformly distributed loads may not be satisfactory. The fatigue effects of the repeated dynamic loading from vehicles on the slab and supporting beams must be considered by the Structural Designer. The suitability of the floor design (beams and slab) for dynamic loading from vehicles should be checked.

Where the concrete is to be used as a wearing surface, or where bonded finishes are specified, the concrete surface should be protected from oil spillage and damage from moving plant.

6.4 Further reading

The references given below relate particularly to this Section. (For information on authors and publishers, see Section 8, References.)

ACIFC and Concrete Society Good Concrete Guide No. 5 – Composite concrete slabs on steel decking – Guidance on construction and associated design considerations^[66]

This Guide is intended to provide an overview of the factors which should be considered in the design of composite slabs with steel decking.

Concrete Society Technical Report No.34, 1994 - Concrete industrial ground floors^[19].

This document provides comprehensive guidance on the design, specification, construction and finishing of industrial concrete ground floors. The guidance on concrete quality requirements for durability, and on finishing procedures, is also relevant to suspended composite slabs.

Concrete Advisory Service Data Sheets

These are produced and published by The Concrete Advisory Service, a subsidiary of the Concrete Society. They provide theoretical and practical advice on matters pertaining to concrete. The sheets referred to in this Section are:

No.8, 1997 Cracking: power trowelled concrete floor slabs^[64]

No.14, 1997 Cracking in composite concrete/corrugated metal decking floor slabs^[28]

The manual and advisory safety code of practice for concrete pumping^[67]

This a specialist guide for concrete pumping contractors which covers in detail both the theoretical and practical sides of pumping concrete.

Guide to steel erection in windy conditions^[68]

This guide provides advice to designers concerning the effect of wind on steelwork during erection. It also explains the role of management and supervision in controlling work as wind freshens, as well as giving comparative information concerning weather forecasts that might be used to plan steel erection.

Guide to the erection of multi-storey buildings^[69]

This document is a code of practice for Steelwork Contractors erecting multi-storey steel-framed buildings. The principles included also apply to high-rise structures generally. The code also provides guidance to Clients, CDM co-ordinators, Principal Contractors and Designers. It describes the management procedures and methods to be adopted when drafting site- and project-specific Erection Method Statements. The document contains advice on the safety aspects of site management; site preparation; delivery, stacking and storage of materials; structural stability; holding down and locating arrangements for columns; lifting and handling; and interconnection of components.

Good construction practice for composite slabs^[70]

This document covers much of the information included in the current guide, but has a bias towards the European market.

National structural steelwork specification for building construction^[71]

This is the industry ‘standard’ for the quality of workmanship associated with the fabrication and erection of steel framed buildings and will often form one of

the contract documents. It includes procedures for shear stud welding and testing.

Health and Safety Executive Guidance Note GS28: Safe erection of structures^[72]

This publication relates to the 1994 CDM Regulations and is currently withdrawn, but an update is awaited. It is expected to provide essential information on safety from the initial planning stage through to site management and procedures, and will help users interpret the Regulations more readily.

Health and Safety in Construction HS(G)150^[73]

This is a comprehensive guide giving practical advice for achieving healthy and safe construction sites. It helps to identify many common hazards and explains control measures. It also deals with planning and management issues, including risk assessment and the Method Statement. It is an essential reference.

7 SLIM FLOOR CONSTRUCTION

This Section describes slim floor construction and outlines its benefits. Aspects of design that differ from those of ‘traditional’ composite slabs and beams (described in Sections 4 and 5) are highlighted. The construction process is described, as are typical construction details. The guidance is aimed at both design and construction personnel.

Boxes are used to highlight issues of good practice in design, or things that the designer should be aware of. They are also used to highlight issues of safety during construction.

7.1 Introduction

Slim floor is a generic term used to describe a form of construction where the supporting beams are contained within the depth of the concrete slab. This is achieved by supporting the slab off the bottom flanges of the beams. Although this concept is not new, it has been significantly refined in recent years, with considerable development work undertaken in the UK by Corus (formerly, British Steel). This work led to *Slimdek* construction, a form of slim floor construction using hot rolled beams together with composite slabs using deep decking. Older forms of slim floor construction, using precast concrete planks to form the slab, are less effective in a number of ways (such as ease of service integration), and are not considered in this document.

Slim floor construction using deep decking is suitable for building layouts requiring the decking, and subsequently the slab, to span up to 9 m. For typical applications, spans vary between 5.5 m and 6.5 m, and the decking does not need propping during construction. This spanning capability means that secondary beams are not normally needed.

The role and structural behaviour of deep decking are similar to those of shallow decking (Section 4), except that the composite resistance of the slab needs to be enhanced by reinforcing bars located in the decking troughs.

A range of beam sections is available (Section 7.1.2). Some of these sections can achieve composite interaction with the slab as a result of the shear bond at the interface between the steel and concrete components, with no need for additional shear connectors.

7.1.1 Benefits

The benefits of composite construction listed in Section 1.1 all apply to slim floor construction using steel decking. It is particularly beneficial in providing the following:

- Shallow floor depth. This may lead to savings in cladding cost, or help to meet overall building height restrictions.
- Ease of service integration. There is a potential to accommodate the services within the slab depth (between the ribs of the decking).
- Inherent fire resistance. A fire resistance of 60 minutes can be achieved without fire protection.

7.1.2 Slim floor components and systems

The most recent slim floor development produced by Corus is the *Slimdek* system. This system comprises *Slimflor* beams and *ComFlor* 225 deep decking. Three different types of *Slimflor* beam are produced: *Slimflor* Fabricated Beams (SFB), Asymmetric *Slimflor* Beams (ASB), and Rectangular Hollow *Slimflor* Beams (RHSFB).

***Slimflor* Beams**

A *Slimflor* Fabricated Beam consists of a Universal Column section with a wide flange plate welded to its underside. This plate supports the slab. Sections ranging from 152 mm to 356 mm nominal depth may be used. Shear connectors can be fixed to the top flange of the beam to achieve composite interaction with the slab. Thin gauge closure pieces, known as 'end diaphragms', are fixed to the flange plate to stiffen the ends of the decking (particularly during concreting), and to form the concrete around the SFB. This type of construction is shown in Figure 7.1.

An Asymmetric *Slimflor* Beam is a hot rolled section with a narrower top flange than bottom flange. The slab is supported off the upper surface of the bottom flange. Composite interaction can be, and usually is, achieved by partial encasement of the section (see Section 7.2.2). Two types of ASB are produced by Corus, one of which has a thicker web. The thicker web type, known as ASB(FE), can be used without fire protection for up to 60 minutes fire resistance. In total, ten different ASB sections are produced by Corus^[74], ranging from a 280 ASB 74 (272 mm deep, 74 kg/m) to a 300 ASB (FE) 249 (340 mm deep, 249 kg/m)). Construction using an ASB is shown in Figure 7.2.

A Rectangular Hollow *Slimflor* Beam is fabricated from a rectangular hollow section with a flange plate welded to its lower face. These beams are more efficient than either SFBs or ASBs in resisting unbalanced loading, and so are ideal for use at the edges of a building. Composite interaction can be achieved by welding studs to the upper flange of the hollow section. Hollow sections up to 500 mm deep may be used, with typical sizes ranging from 200 mm to 300 mm depth. Construction using a RHSFB is shown in Figure 7.3.

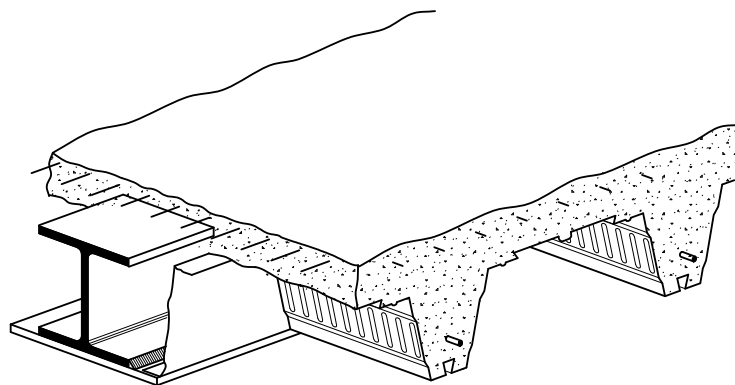

Figure 7.1 SFB with deep decking (non-composite beam)

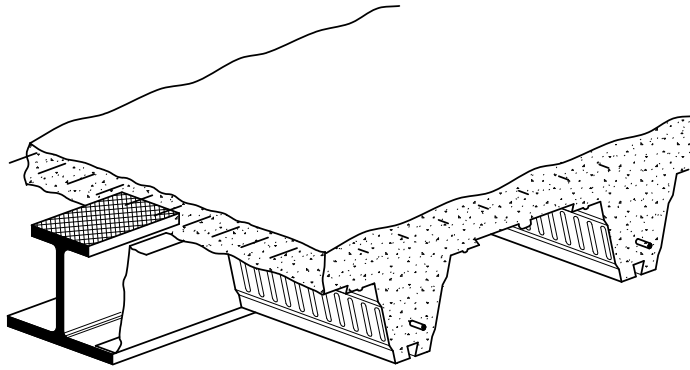

Figure 7.2 ASB with deep decking (composite beam)

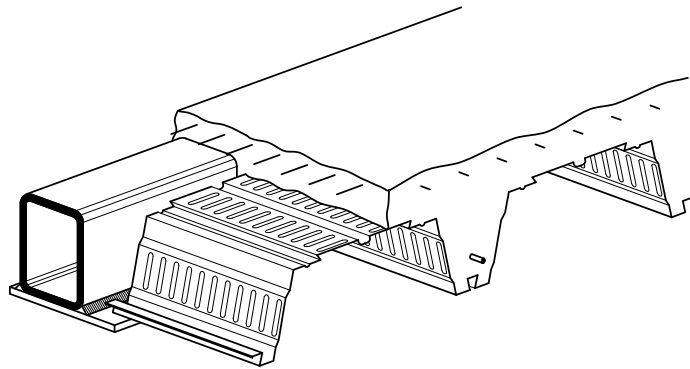

Figure 7.3 RHSFB with deep decking (non-composite beam)

ComFlor 225 deep decking

The *ComFlor 225* profile is the most recent form of deep decking, and it may be used with any of the beam types described above. Its cross-section is illustrated in Figure 7.4; the profile includes provision for special attachment points for services and/or a suspended ceiling. A cut-out is included at the top of each rib to ease concrete placement around the beams. The decking is produced in 600 mm wide units, normally from 1.25 mm thick grade S350 galvanized steel. Typical floor construction using *ComFlor 225* decking is shown in Figure 7.5.

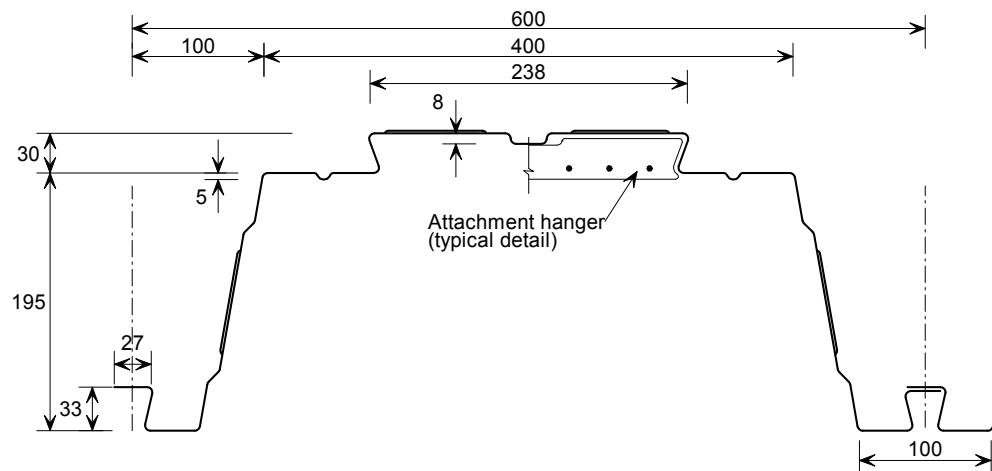

Figure 7.4 Cross-section of *ComFlor 225* deep decking profile, showing a typical service attachment detail.

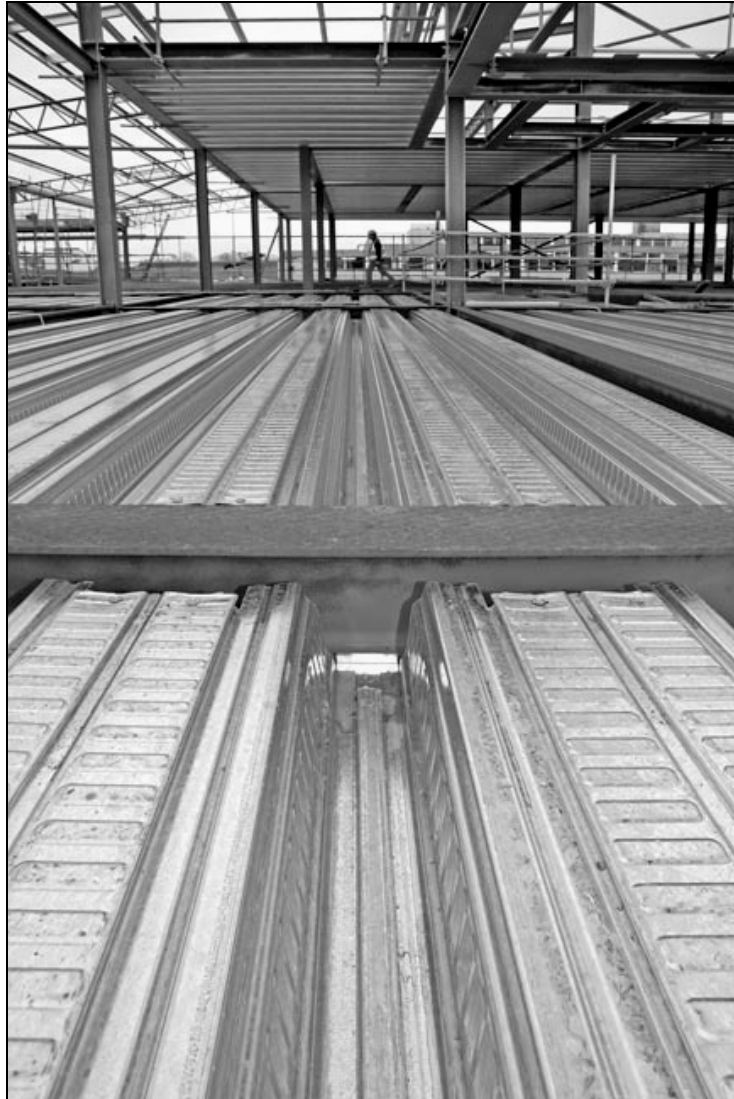

Figure 7.5 View of Slimflor construction using ComFlor 225 decking.

7.2 Design

Detailed methods for the design of all the components in the *Slimdek* system are presented in References 75, 76 and 77, as well as being summarised in the *Corus Slimdek Manual*^[74]. Design software for the beams and decking, *Slim Floor Integrated Design Software* – SIDS[®] [78], is available from Corus at www.corusconstruction.com. The software designs and analyses flooring solutions utilizing both *Slimflor*[®] Fabricated Beams (SFB) and Asymmetric *Slimflor* Beams (ASB).

There are two distinct stages for which the elements of the *Slimdek* system must be designed. The first is the construction stage, during which the beams and decking support the loads as non-composite sections. The second is the final stage, during which the decking and concrete act together compositely, as do (generally) the ASBs and slab. SFBs and RHSFBs will act compositely if shear studs have been provided. A summary of the key design considerations for both of these stages is given below.

The sequence of design activities generally follows that given in Figure 2.1. The following two points should be noted:

- Consideration of the required spans will allow the depth of the beams to be estimated.
- Consideration of the required fire resistance will allow the depth of slab to be estimated, as a function of the cover required for the beams and the decking.

Having established these scheme design parameters, detailed design of the beams and slab can be undertaken. The following slab depths should be considered as typical:

- 280 ASB sections ~ 290-320 mm deep slab
- 300 ASB sections ~ 315-340 mm deep slab.

These depths will enable adequate cover to the ASB for it to act compositely with the slab. For SFBs a greater range of slab depths may be considered for a given depth of beam; the slab depth requirement will depend on whether shear studs must be accommodated to make the SFB act compositely.

7.2.1 Construction stage

Beam design

Design of the beams at the construction stage is essentially the same as for conventional steel beams. It may control the size of the beam when the in-service imposed loads are small. The one significant difference arises from the fact that in *Slimdek* construction the bottom flange (or flange plate) is loaded by the weight of the wet concrete and construction loads. The flange (or plate) must be designed to carry this loading in 'transverse' bending, at the same time as acting in tension as part of the beam section.

Out-of-balance loading from one side during construction results in torsion being applied to the beam. This is resisted by the beam and its end connections.

Two load conditions should be considered:

- uniformly distributed load on one side of the beam, causing maximum torsion in the beam
- uniformly distributed load over the entire supported area, causing maximum bending moment in the beam.

Check that the steel beam size chosen is capable of supporting the wet weight of the concrete, and other construction loads, in its non-composite state.

Check for the worst case combination of 'transverse' and 'longitudinal' bending. Loading on one side of the beam only will often dictate the required section size.

Decking design

In addition to considering the self weight of the slab, the design of the deep decking should take into account temporary construction loads. It is recommended that the construction loads specified in the Eurocodes are used for the design of deep decking, and not those specified in BS 5950-4, which are considered unduly onerous for long span decking. The specified loads are the

same as for shallow decking, and are explained in detail in Section 4.1.2. They include a 3 m length construction load of 1.5 kN/m^2 , which may be placed anywhere for the most onerous effect, and adjacent loads of 0.75 kN/m^2 .

The effect of concrete ponding should be taken into account (by increasing the self weight of the slab) if the deflection under self weight alone exceeds the lesser of span/180 or 20 mm.

If temporary props are used to support the decking during construction, the 3 m length construction load of 1.5 kN/m^2 should be applied in the most onerous positions for the prop and the decking design, although, for design simplicity, a constant load could be considered across the span for these 'propped' design conditions.

It is likely that deep decking will require propping during construction if it is required to span more than about 6.5 m. The precise limit depends on whether lightweight or normal weight concrete is used. The spacing of the props is governed by the ability of the decking to resist combined bending and shear in the hogging (negative) moment regions over the lines of props. It is recommended that the spacing between the props should be relatively close, so that local loads do not cause damage to the decking (2.5 m to 3.5 m spacing depending on the slab weight^[79]). A 100 mm wide by at least 40 mm thick timber bearer should be used to distribute the load at these points.

The nominal end bearing of the sheets should be specified as 50 mm. The flange widths are such that this bearing can be achieved, whilst still allowing the sheets to be dropped vertically into position (i.e. without having to 'thread' them between the top and bottom flanges). It should be noted that a nominal bearing length of 50 mm has been justified^[74] by recent testing (earlier publications suggested that 75 mm was necessary).

It is not necessary for the deep decking to be designed to support 1.5 kN/m^2 over its entire span. Half this value may be considered outside the 'middle 3 m', although when the slab is propped it may be prudent to design for a constant 1.5 kN/m^2 .

Allow for increased self weight due to concrete ponding when deflections are substantial.

Specify an end bearing length of 50 mm. Any less would be insufficient to achieve the necessary resistance to local loading, any more would make the decking sheets more difficult to drop into position.

7.2.2 Final stage

Beam design

ASBs will in most cases be designed to act compositely in the final stage. Composite action is developed by the shear bond between the steel and concrete around the beam, and this is enhanced by the raised pattern rolled into the top surface of the beam. The bond is sufficient to satisfy the minimum degree of shear connection required by BS 5950-3. Only in unusual cases, for example when there is less than 30 mm concrete cover over the top flange, will a non-composite design be necessary. This will mean that section sizes may have to be increased for given span and loading requirements.

SFBs may be designed either non-compositely or compositely. Composite action can be achieved by the use of shear studs welded to the top flange. These studs are usually 19 mm diameter and 70 mm as-welded height.

RHSFB edge beams may be designed either non-compositely or compositely. As for SFBs, composite action can be achieved by the use of ‘short’ shear studs welded to the top flange. Sufficient transverse reinforcement looped around the shear connectors is required in order to transfer the shear force into the slab^[75].

For ASBs, SFBs and RHSFBs, the minimum concrete cover required for the beams depends on the beam size, exposure conditions, the concrete specification and composite interaction is required.

The plastic stress blocks assumed when calculating the moment resistance of a composite ASB section are shown in Figure 7.6. The resistance model for a composite SFB or RHSFB is basically the same as that for a ‘traditional’ composite beam (Section 5.2.1), with a requirement to consider the ability of the shear studs to transfer the envisaged longitudinal force.

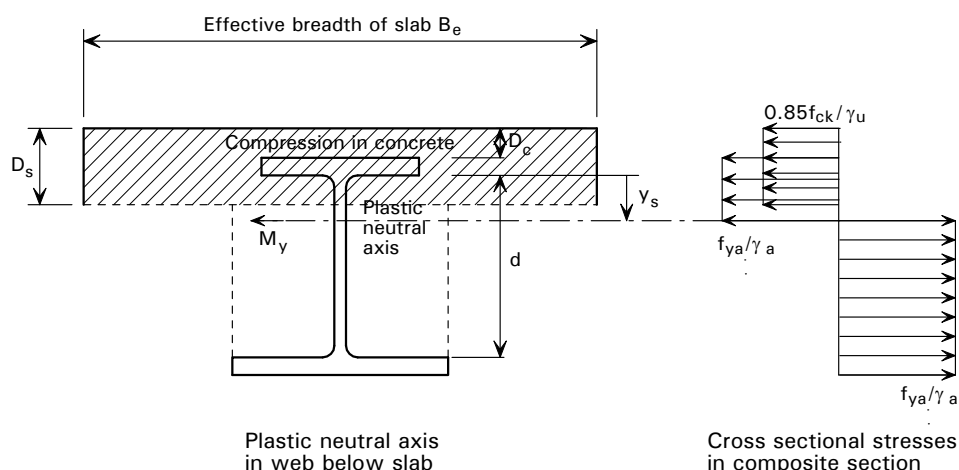

Figure 7.6 Assumed stress blocks for ASB design (using BS EN 1994-1-1 notation)

For edge beams, or beams adjacent to openings in the slab, out-of-balance loading occurs during both the construction and final stages. This may be taken into account by a rigorous analysis combining the longitudinal bending effects with the torsional effects. A method is presented in Reference 79.

If possible, sufficient concrete cover should be provided to allow composite interaction between the beams and slab. This will generally allow the beam sizes to be reduced.

Slab design

The design of composite slabs using deep decking differs from that for shallow decking (Section 4.2) in the following ways:

- The ultimate load resistance of the slab is increased by placing bar reinforcement in the troughs of the decking. The benefit of these bars is considered in both the ‘normal’ and fire conditions.
- The slab depth may need to be chosen not only to satisfy the structural, durability and fire resistance requirements of the slab itself (see

Sections 4.2.3, 4.2.4 and 4.2.5), but also to provide appropriate cover over composite beam sections (Section 7.2.2).

The reinforcing bars in the troughs of the decking provide additional tensile area to that provided by the decking, and thus enhance the bending resistance of the composite slab (Figure 7.7). Diameters range from 16 mm to 32 mm, depending on the span and fire resistance requirements.

Straight bars may be used to achieve 60 minutes fire resistance (provided that shear stresses are low^[74]). In other cases, L bars (see Figure 7.8) should be used to provide sufficient end anchorage in fire conditions. Detailing rules are summarised in Table 7.1 and Figure 7.8.

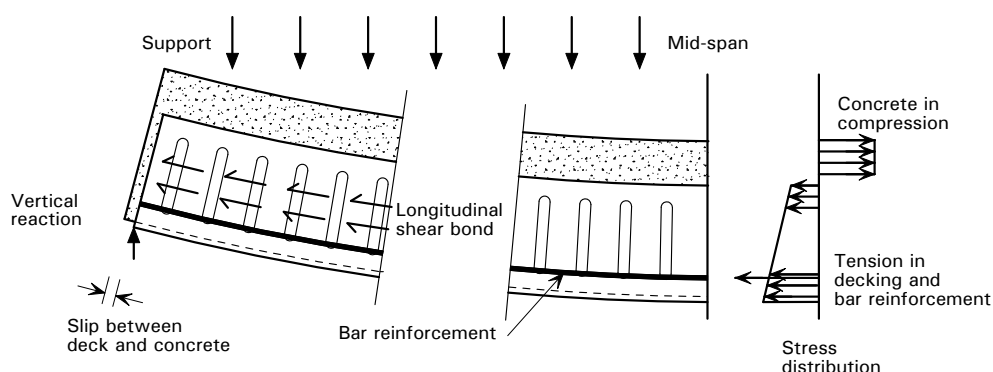

Figure 7.7 Action of composite slab with reinforcement in ribs

Table 7.1 Detailing requirements for deep composite slabs

Detailing Requirement	Fire Resistance (min)		
	≤ 60	90	120
Minimum bar dia (mm)			
- unpropped	16	20	25
- propped	20	25	32
Cover to bar (mm)	70	90	120
Bar type	Straight	L-bar	L-bar
Min fabric in topping	A142	A193	A252

The minimum anchorage details depend on the level of applied shear and the diameter of the main reinforcing bars in the rib, which in turn depends on the fire resistance period and whether or not the slab is propped. For 60 minutes fire resistance, when the level of applied shear is less than 0.5 times the available shear resistance, straight bars may be used without extra anchorage bars - in accordance with BS 8110-1:2005^[30], clause 3.12.9.4. However, anchorage bars are recommended even for low values of applied shear at 90 and 120 minutes fire resistance periods.

For more details see Reference 74.

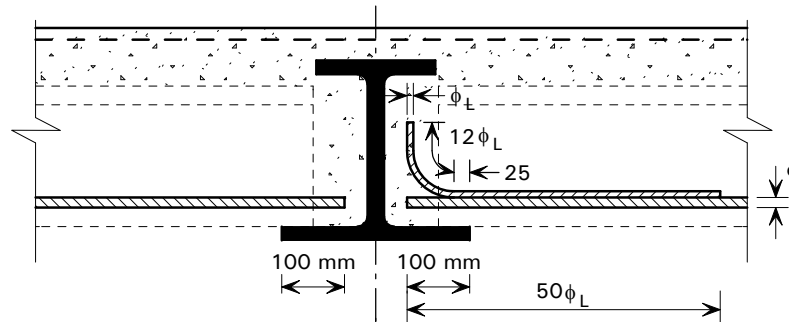

Figure 7.8 Detailing of bar reinforcement in slabs (need for L bars depends on level of shear stress)

Additional reinforcement may be required to fulfil the following roles:

- Transverse reinforcement adjacent to shear connectors.
- U-bars at composite edge beams.
- Additional crack control reinforcement (see below).
- Strengthening around openings.
- Strengthening at positions of concentrated loads.

One of the principal considerations governing the choice of slab depth is the required fire resistance period. Minimum depths are given in Table 7.2^[74] as a function of the concrete type and fire resistance required.

Table 7.2 Minimum concrete depth above decking for adequate fire insulation

Fire Resistance (mins)	Concrete Depth Above Decking (mm)		Note: Depths given are the minimum for fire insulation purposes. Greater thicknesses may be required for spanning capability, or to achieve adequate beam cover.
	Normal concrete	Lightweight concrete	
60	70	60	
90	80	70	
120	90	80	

The slab depth may also be governed by structural resistance requirements. However, as for shallow decking (Section 4.2.3), the performance of a composite slab using deep decking can only be accurately determined by testing. Detailed design procedures have been developed based on appropriate tests^[74], and should be used to determine the depth of slab needed to satisfy structural requirements.

It is normal for some cracking to occur in the slab over the beams. These cracks run parallel with the beams and are not detrimental to the structural behaviour of the slab. They may be controlled by fabric reinforcement provided across the tops of the beams. Guidance on the detailing of reinforcement to control cracking may be found in the Corus *Slimdek* manual^[74].

7.2.3 Service integration

There are three opportunities for service integration in the *Slimdek* system:

- Partial integration: Major services pass below the slab and beams and the space between the ribs is used for small pipes and fittings, such as lighting units. This allows for cross-overs of ducts or pipes. The absence of downstands provides for greater flexibility of service distribution and reduces the depth of the structure-services zone.
- Full integration: Circular or elongated openings formed in the webs of the beams for ducts and pipes located between and within the depth of the ribs to pass through the beams. (Alternatively, the space between the ribs can act as a duct in itself, which again continues through the openings in the beams.)
- Slab penetrations: Services can pass vertically through openings (up to 400 mm wide by 1 m long) in the concrete topping between the ribs. Larger openings can be formed, but require more detailed design.

In certain areas where spans are relatively short (< 3.5 m), shallower floors may be created locally, using a composite slab of 120 to 150 mm depth comprising more traditional decking of 50 to 60 mm depth. This is particularly useful in, or adjacent to, core areas where duct cross-overs and horizontal bends are required without deepening the ceiling-floor zone excessively.

Web openings

Full integration of services can be achieved by providing openings through the beam web midway between the ribs of the deep decking. During fabrication, an opening (usually circular or oval) is cut in the web. The same sized openings are also cut in the diaphragms that fit between the ribs and a 'sleeve' is placed through the beam and diaphragms before the concrete is placed. The elements that form the opening are shown in Figure 7.9. Flat, oval or circular ducts may be placed inside the sleeve and sealed externally.

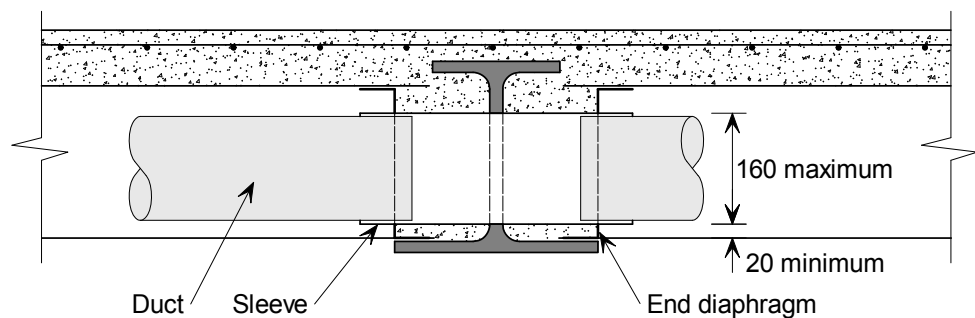

Figure 7.9 *Forming openings through ASB*

Maximum acceptable sizes, and positions, for openings in the webs of ASBs have been established by full-scale tests:

ASB sections:

- Provide elongated openings up to 160 mm deep by 320 mm long centrally between the ribs over the middle half of the beam span, but not within 1500 mm from the supports.
- Alternatively, provide circular openings up to 160 mm diameter, but not within 1000 mm from the supports.

- Ensure that the base of all openings is 20 mm above the bottom flange, independent of their depth. This avoids the root radius of the section and fits the openings within the decking shape.

ASB (FE) sections:

- Provide elongated openings up to 160 mm deep by 320 mm long centrally between the ribs, but not within 450 mm from the supports.
- Alternatively, provide circular openings up to 160 mm diameter.
- Ensure that the base of all openings is 20 mm above the bottom flange, independent of their depth. This avoids the root radius of the section and fits the openings within the decking shape.

Detailing rules for web openings are summarised in Figure 7.10.

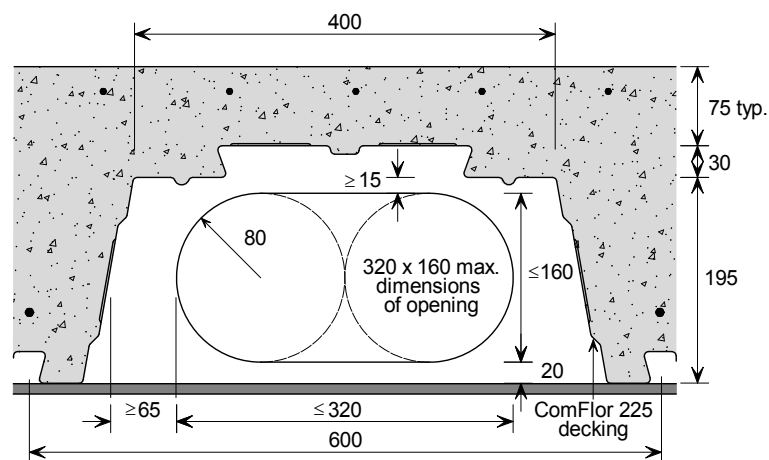

a) Maximum size of opening

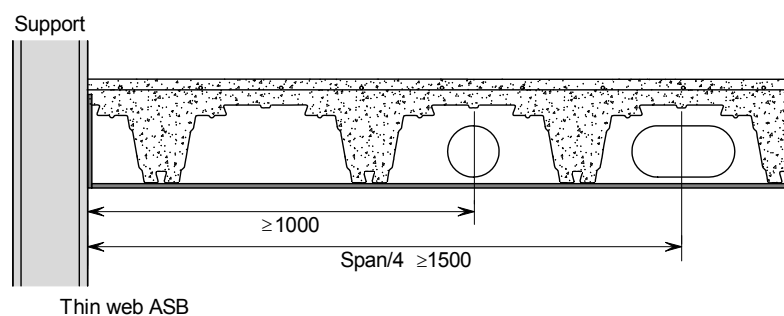
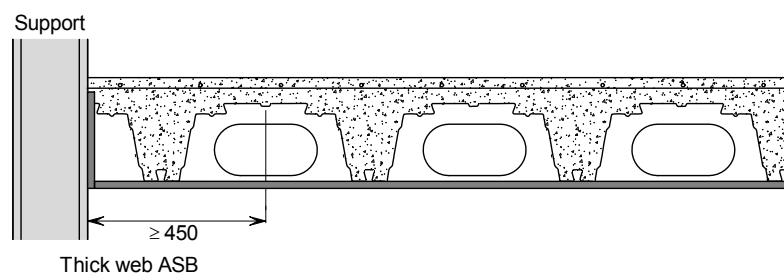

b) Location of openings

Figure 7.10 Detailing rules for web openings in ASB a) maximum size of openings b) location of openings

Maximum acceptable sizes, and positions, for openings in the webs of SFBs have also been established by testing. The base of all openings should be detailed approximately 20 mm above the top of the bottom flange of the UC. Combinations of elongated openings up to 160 mm deep by 240 mm long, and circular openings up to 160 mm in diameter, may be accommodated in different parts of a span. Full details of maximum sizes and allowable positions are given in Figure 7.11.

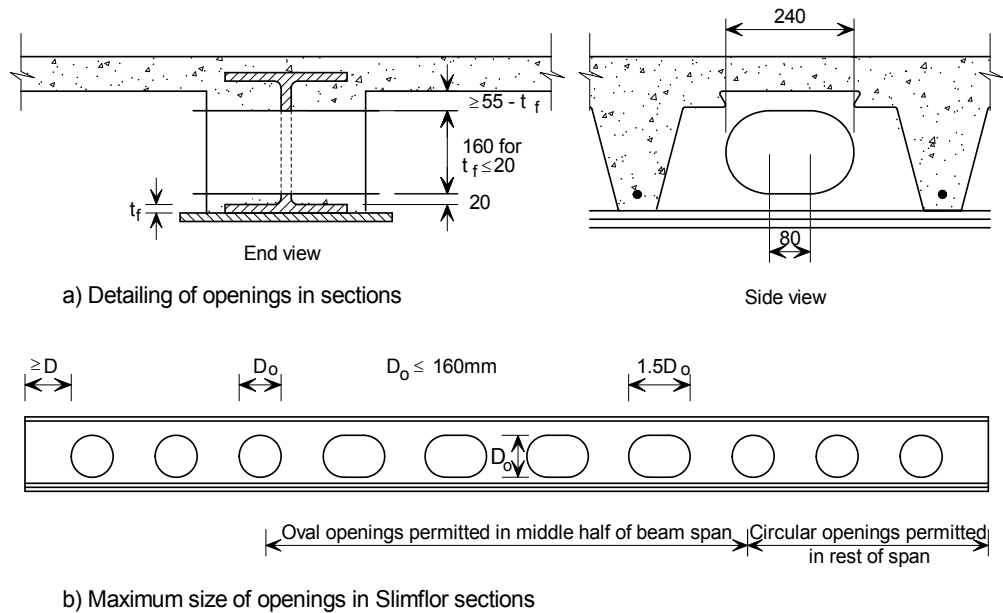

Figure 7.11 Detailing rules for web openings in SFB a) maximum size of openings b) location of openings

Web openings affect the shear resistance, the bending resistance, and the second moment of area of a beam. Empirical formulae for predicting revised properties for ASB and SFB sections, as a function of the opening geometry, may be found in Reference 74. Design allowing for openings is also included in design software available from Corus.

Openings may also affect the fire resistance of a section. ASB sections with openings invariably require fire protection to the bottom flange for 60 minutes fire resistance (and above) for economic design. However, for 30 minutes fire resistance, ASB sections with openings do not require fire protection.

One of the major benefits of the *Slimdek* system is its ability to accommodate services. Substantial web openings may be formed in the beams, but the designer must adhere to strict empirical rules concerning the position and size of the openings, and their influence on beam behaviour.

Openings in the slab

Provision for vertical service openings within the floor slab will necessitate careful design and planning. The following list summarises the options that are available to the designer (see Figure 7.12):

- Openings up to 300 mm × 300 mm can be accommodated anywhere in the slab over a crest section of the deck, normally without needing additional reinforcement.

- Openings up to 400 mm wide \times 1000 mm long may be taken through the crest of the *ComFlor 225* decking. Additional reinforcement, which should be designed in accordance with BS EN 1992-1-1^[24] (or BS 8110^[30]), may be required around the opening.
- Openings up to 1000 mm wide \times 2000 mm long may be accommodated by removing one rib (maximum) of the decking, fixing suitable edge trims and providing additional reinforcement to transfer forces from the discontinuous rib. The slab should be designed as a ribbed slab in accordance with BS EN 1992-1-1 (or BS 8110), with the decking being used as permanent formwork. Guidance may be found in the Corus *Slimdek Manual*^[74].
- Larger openings will generally require trimming by secondary beams.
- Openings required in the slab should be made using shuttering or void-formers, and the decking cut after curing – unless properly supported during construction or permanently trimmed.

If an opening greater than 300 mm \times 300 mm lies within the effective width of slab adjacent to a beam (L/8), the beam should be designed as non-composite. A close grouping of penetrations transverse to the span direction of the decking should be treated as a single large opening.

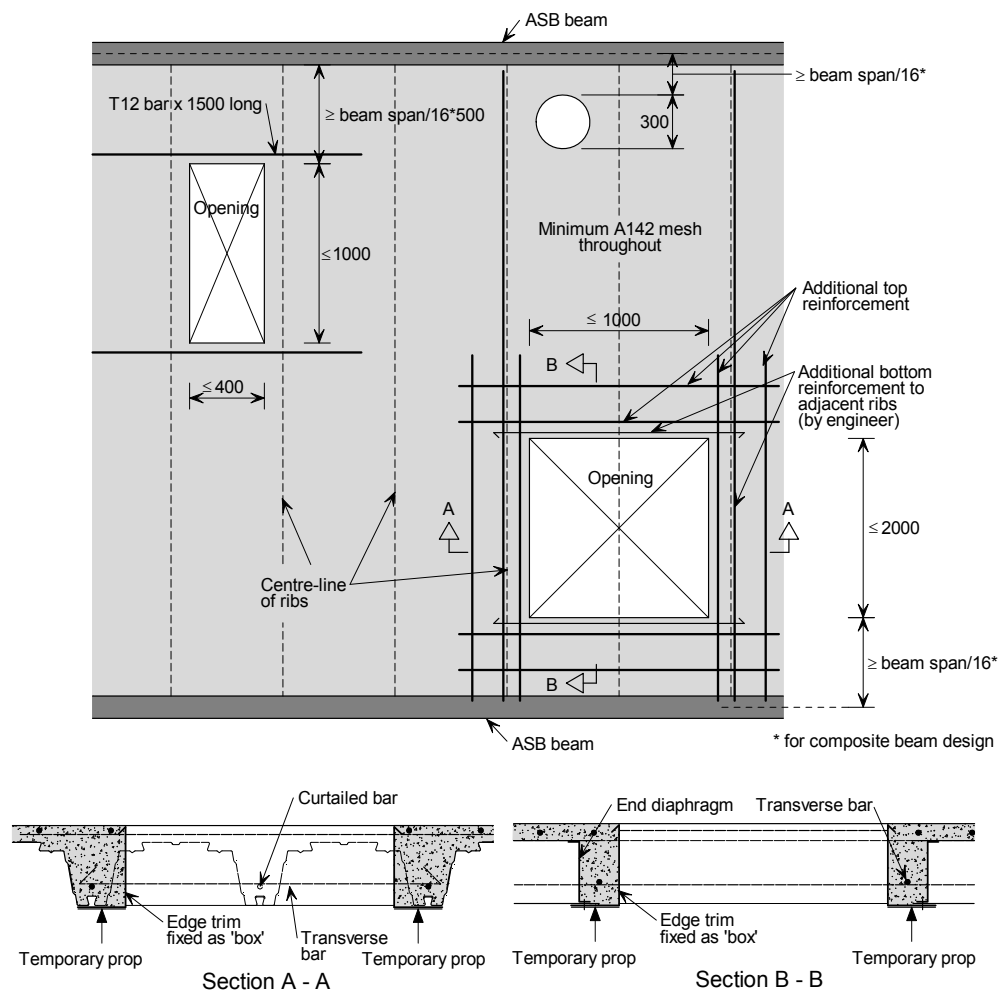

Figure 7.12 Details of small and medium size openings in the slab.

A range of possibilities exist for passing services vertically through the slab. The designer should recognise that some of these have implications for the permanent works design, e.g. the need to specify additional reinforcement and/or trimming steel.

Service attachments

The *ComFlor 225* decking facilitates the fixing of services and suspended ceilings. Hangers can be used to support services running either parallel or perpendicular to the decking span.

The new adjustable Lindapter *Slimdek 2* fixing clip¹⁸⁰¹ can achieve a safe working load of 1.0 kN per fixing. These allow service pipes to be suspended directly from the decking between the ribs. Alternatively, self-drilling self-tapping screws may be used to attach hangers to the decking after the concrete has been placed but care is required when attaching fixings to ensure that the bond between the decking and concrete is not impaired.

Service integration is covered in detail in *Service integration in the Slimdek system*³⁵¹.

7.2.4 Construction details

Ends of decking

Often, it is necessary to use part width sheets of decking, particularly at tie beams or at slab edges. When a part width is specified, a Z section is needed to provide local support to the decking, as shown in Figure 7.13. This should be identified on the decking layout drawing (Section 3.2).

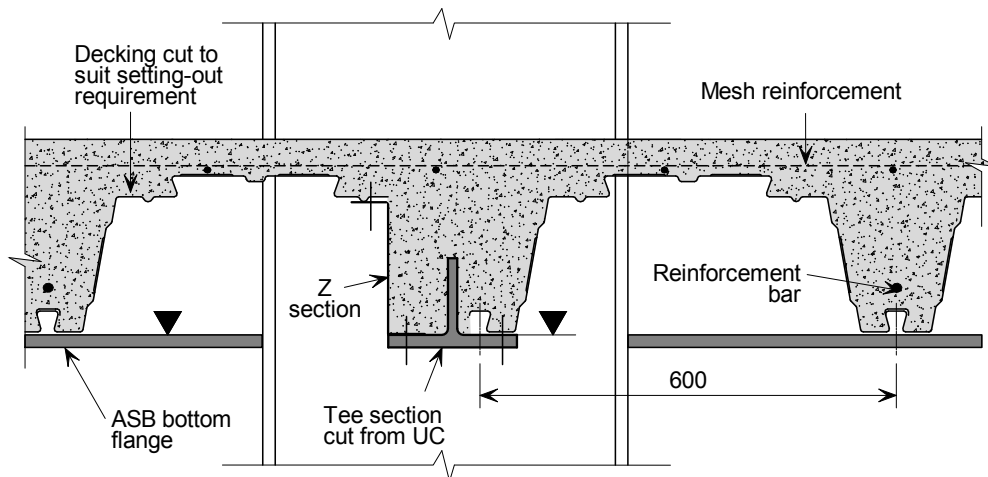

Figure 7.13 Z section to support edge of decking at a tie beam

Slab edges

There are various alternatives for edge beams in *Slimdek* construction. These are:

- Conventional downstand beams
- Rectangular Hollow Section *Slimflor* Beams
- Asymmetric *Slimflor* Beams.

Typical details for edge beams are shown in Figure 7.14. There are some critical dimensions that should be noted:

- In detail (a) the concrete cover to the RHSFB should either be zero or greater than or equal to 40 mm
- In detail (b) the concrete cover to the composite RHSFB should be at least 15 mm greater than the as-welded height of the studs (85 mm for 70 mm long studs)
- In detail (c) the minimum distance from the edge trim to the top flange of the beam should be 125 mm (to allow access for a fixing tool) and maximum overhang of the trim from the bottom flange should be 150 mm.

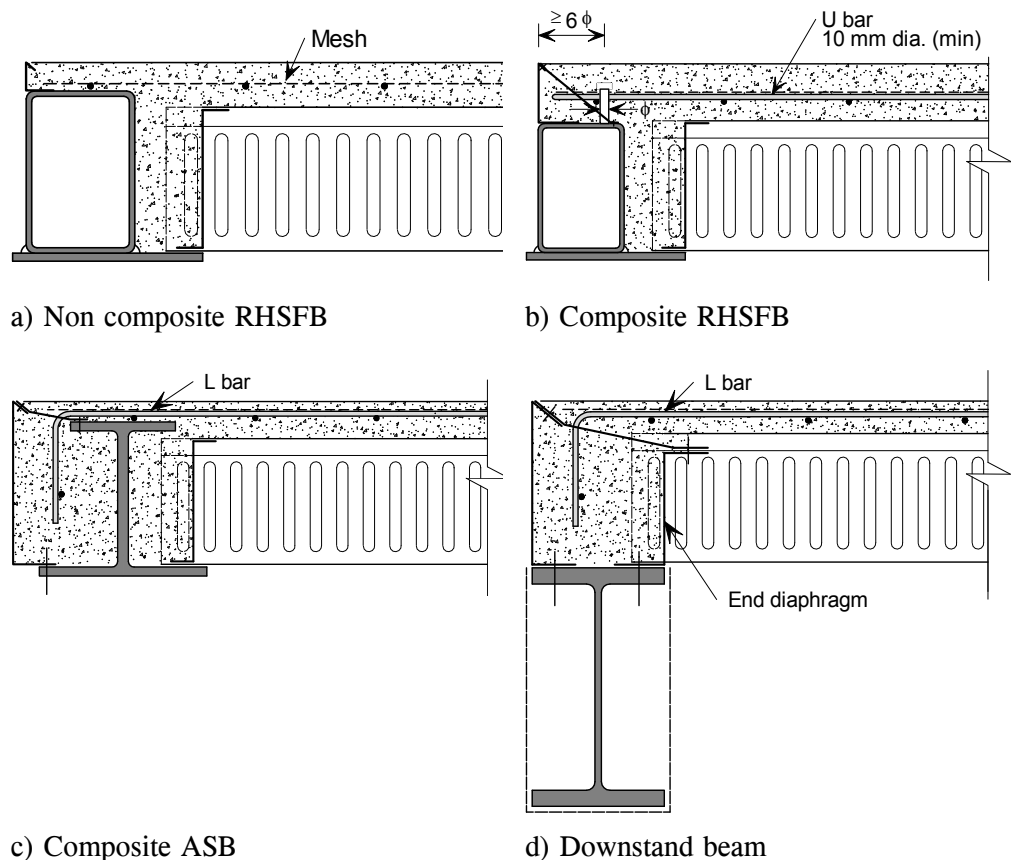

Figure 7.14 Typical edge beams.

Column ties

Tie members are required between columns, perpendicular to the main beams, in order to provide:

- Stability during construction.
- Robustness and stability of the completed construction.
- Transfer of forces (e.g. due to wind action).

The tie members may be of various forms, as illustrated in Figure 7.15, the most common being:

- T sections in which the flange of the T provides support to the decking.
- RHS sections with a bottom plate to support the decking.

- Lighter ASB sections, especially adjacent to openings.
- Fire protected RHS sections not encased in the slab.

Advice on tying requirements for robustness may be found in Reference 81.

Connecting decking to the bottom flange of I beams often presents practical difficulties on site because the fixing tool cannot be fitted in the space between the web of the decking and the beam flange. Therefore, the use of an ASB beam or a RHS with welded bottom plate is preferred. Where the T or RHS members are encased in the slab, a shelf plate should be welded to the column web to provide local support to the decking.

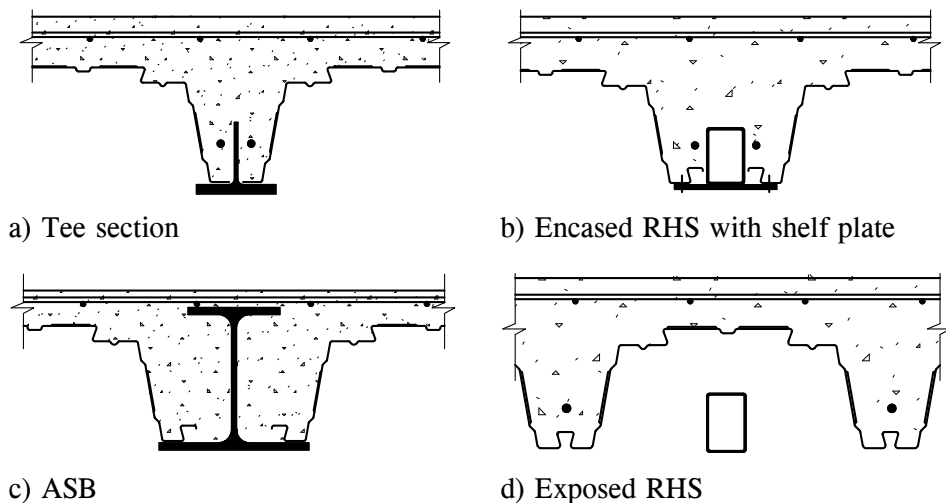

Figure 7.15 *Alternative forms of tie members*

7.3 Construction practice

Good practice for receiving, storing, and placing bundles of deep decking on the steel frame is essentially the same as for shallow decking. However, because of the use of end diaphragms, there is a significant difference in the procedure adopted for placing and fixing the decking. *Slimdek* designers and installers should refer to the *BCSA Guide to the installation of deep decking* ^[82]. This publication carries detailed description of safe installation procedures.

Planning

Deep decking is similar to shallow decking in that good planning on the part of the designers is essential for the success of the project. In particular, with deep decking it is quite common for designers to show details that are impossible to install; these of course should be avoided and the Corus standard details (available for download from the Corus website) always used. Some typical details to avoid are shown in Figure 7.16. In the figure, details (a) and (b) are possible with an appropriate steel angle or timber support (see Figure 4.6). Detail (c) is not possible when the clearance between the top flange of the ASB and the edge trim is less than 110 mm because of inadequate access to fix the trim on the bottom flange. This can be remedied by detailing the trim and slab to cantilever slightly. Welding a flange plate to the section on which to support the decking is one option to avoid the problems caused by detail (d). Detail (g) is not possible because of inadequate access to fix the trim on the section bottom flange. A solution is to extend the flange plate (by at least 110 mm) to enable

the edge trim to be fixed directly to it. The table of the angle in detail (h) needs to be extended to provide the access needed (see Figure 4.6). The problems associated with detail (j) can be overcome by adding a flange plate to the RHS member and setting it at a level where the decking can be supported either side of it on the flange plate.

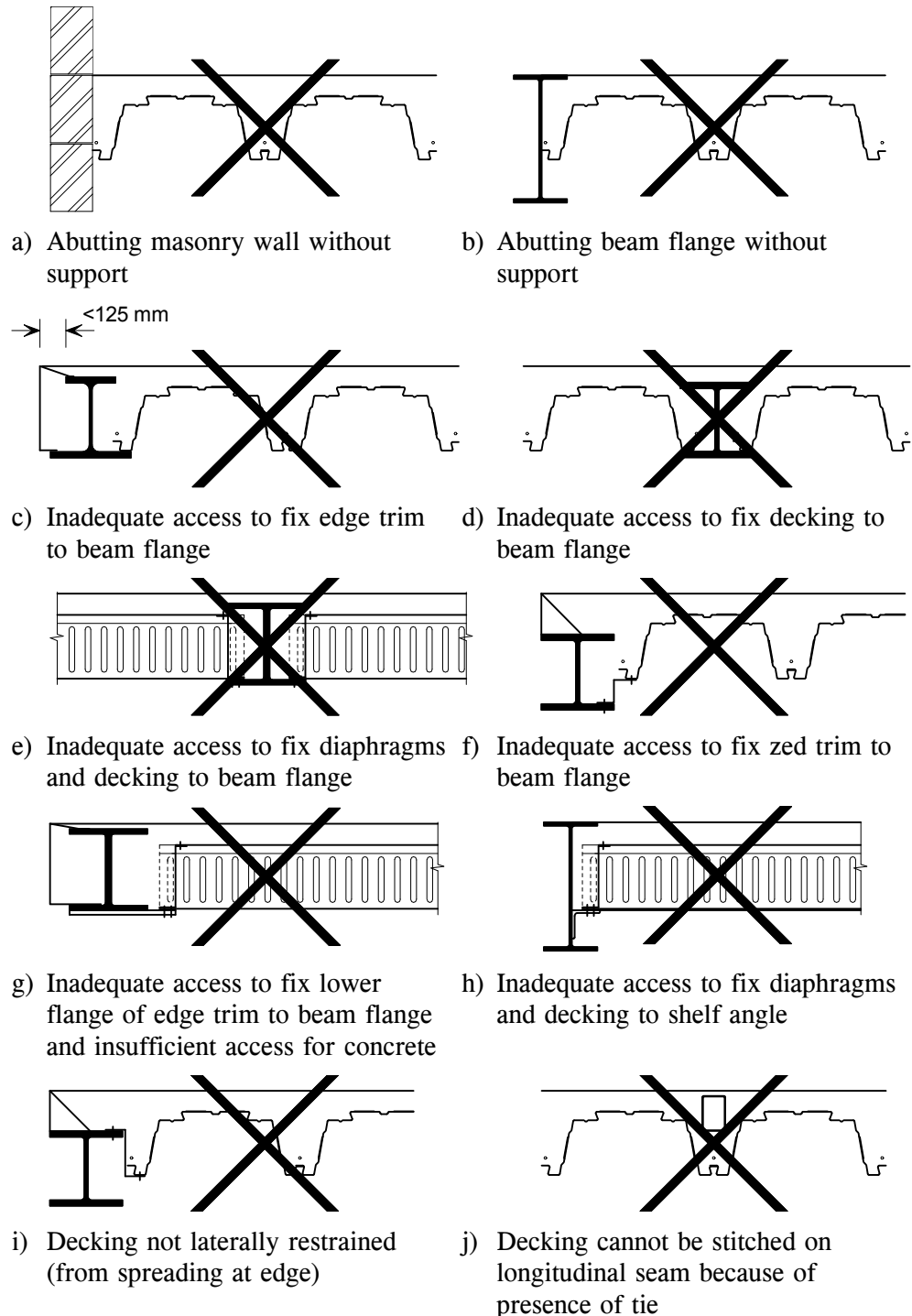

Figure 7.16 *Unsuitable decking details*

Other important planning points include:

- Ground conditions - it is even more important for deep decking than for shallow decking that there is a hard, flat, well-compacted surface for the decking installer to work from within the building footprint. This is because

deep decking uses diaphragms that are generally fitted from a work platform or MEWP (see below).

- The location of the perimeter edge protection needs to be considered at an early stage, and should be fitted at an offset from the perimeter beams because the deckers need to work from these to lay the decking sheets.
- Decking bundles must be correctly positioned as indicated on the Decking Contractor's drawings, to minimise unnecessary manual handling and the need for operatives to traverse open steelwork.

Placement and fixing of decking

Following erection of the permanent steelwork, the following procedure should be adopted for installing and fixing a panel of deep decking on *Slimflor* beams.

The end diaphragms are fixed first, as shown in Figure 7.17. These are supplied in lengths of 1800 mm, which equates to three sections of *ComFlor 225* decking. They are fixed to the edges of the lower flanges of the beams on both sides (except for edge beams), using at least two shot-fired pins for each length. The diaphragms should be installed from a work platform wherever reasonably practicable. Access systems such as MEWPs or Mobile Scaffold Work Platforms can be used if the ground conditions are adequately levelled and compacted, including the areas around the column bases.

Decking installation should only commence once the end diaphragms and safety net (or alternative) fall arrest system are in place. The decking sheets are then manually lowered individually onto the beams. The nominal end bearing of the sheets should be 50 mm; the flange widths are such that this can be achieved, whilst still being able to drop the sheets vertically into position (i.e. without having to 'thread' them between the top and bottom flanges). The bearing length should never be less than 40 mm. As it is often not possible to straddle the steelwork once the end diaphragms are in place, decking operatives will usually stand on the top flange of the beam at either end of the first bundle of decking to cut open the steel banding and lift the first decking sheet out onto the steelwork and over the pre-fitted diaphragms. Decking sheets should always be positioned by a minimum of two operatives. Where sheets are longer than 6 m, decking should be positioned preferably by two operatives at each end of the sheet using an extended handlebar lifting device, unless mechanical lifting systems are available.

Once the sheets for the whole bay are in place, they are secured to the beam lower flanges using heavy duty shot-fired fixings, and to the top of the diaphragms using self drilling self tapping screws.

Light steel edge trim is used to form the edges of the slab and to infill where the 600 mm profile of the decking does not align with the parallel supports. These sections are custom manufactured for each project, and will be detailed on the decking layout drawing (Section 3.2).

The decking forms a part of the slab reinforcement, with the remainder being supplied by a bar in each trough of the decking and a fabric placed near to the top of the slab. Reinforcement should be fixed in accordance with the requirements of the Structural Designer (or Delegated Designer). Normally, spacers are used to position the bars 70 mm from the base of the trough. This distance will increase to 90 or 120 mm (respectively) when 90 or 120 minutes fire resistance are required. There may be additional fabric or bar reinforcement

to fix adjacent to supports or edge beams, or above beams for crack control purposes.

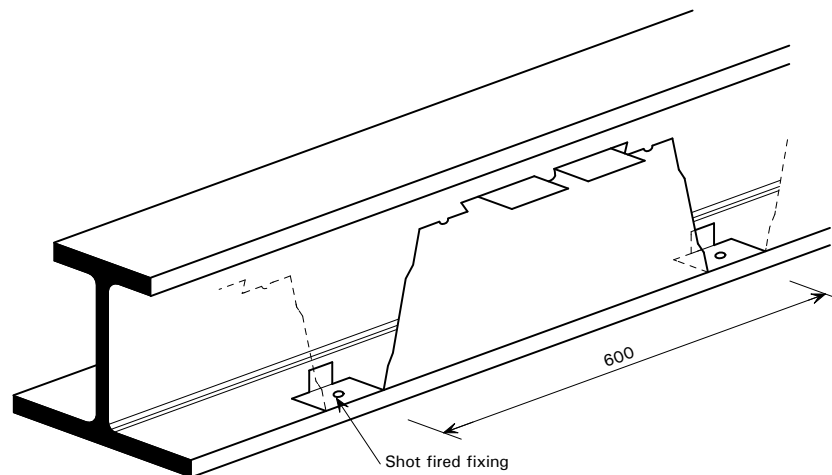

Figure 7.17 Fixing of end diaphragms at ASB

Having fixed the reinforcement, the Main Contractor completes the floor slab by providing any necessary temporary propping and finally concreting the slab. It is important to ensure that the concrete is properly compacted, and a poker is needed to ensure proper concrete flow around the beams, beyond the ends of the decking.

Any shear studs that are required (to make SFBs or RHSFBs composite) may be welded to these sections during fabrication, because they do not interfere with the decking. If they are to be welded on site, the precautions and procedures outlined in Section 6.5 should be considered.

Propping

For long spans the decking should be propped; requirements will have been identified by the Structural Designer and indicated on the decking layout drawings. Props should be in place prior to placing the decking, for spans of 7.5 m or more; the props will provide an additional support point for the sheets when they are being lowered into position on the beam flanges. In all cases props should be stable without relying on friction with the decking for lateral stability. The end props in a row should be self supporting and braced to the internal props.

If it is necessary to prop the beams, the supports should be much more robust than those used to support decking. Generally, a 'Tri-shore' or braced propping system will be required. These props should be placed at a minimum of 3 m spacing along the beams. It will often be necessary to prop to two levels below the supported beam to avoid creep-induced deflections of the supporting beam.

Very short lengths of decking

Where the beam spacing demands a length of decking of 1 m or less, especially where the beams are not parallel, it is far more efficient to use a shallow composite floor deck. This eliminates the need for close spaced diaphragms and complicated cutting of very short pieces of *ComFlor 225*.

7.4 Further reading

The references given below relate particularly to this Section. (For information on authors and publishers, see Section 8, References.)

Corus Slimdek Manual^[74]

This is an essential reference as it covers all aspects relating to the design and construction of the *Slimdek* system.

BCSA Guide to the installation of deep decking^[82]

This publication carries a detailed description of safe installation procedures for deep decking.

8 REFERENCES

- 1 Composite Flooring Systems: Sustainable construction solutions
MCRMA, 2003
- 2 Better value in steel - Composite flooring - floors using steel decking
(P285)
The Steel Construction Institute, 2001
- 3 HICKS, S.J, LAWSON, R.M, RACKHAM, J.W, and FORDHAM, P.
Comparative structure cost of modern commercial buildings - Second
Edition (P137)
The Steel Construction Institute, 2003
- 4 Managing health and safety in construction
Construction (Design and Management) Regulations 2007. (CDM)
Approved Code of Practice (Series code L144).
HSE Books, 2007
- 5 BROWN, D.G.
The Construction (Design and Management) Regulations 1994:
Advice for designers in steel (P162)
The Steel Construction Institute, 1997
- 6 Code of Practice for metal decking and stud welding (Ref 37/04).
BCSA, 2004
- 7 AD 175: Diaphragm action of steel decking during construction
Advisory Desk, in New Steel Construction, Vol 3 (4), Aug 1995
- 8 BS EN 10326: 2004 Continuously hot-dip coated strip and sheet of
structural steels. Technical delivery conditions
BSI
- 9 AD 247: Use of composite construction in an aggressive environment.
Advisory Desk, in New Steel Construction, Vol 9(2), March 2001
- 10 BS EN 1991-1-6:2005 Eurocode 1. Actions on structures. General
actions. Actions during execution
BSI
- 11 BS 5950: Structural use of Steelwork in Building:
BS 5950-1:2000 Structural use of steelwork in building. Code of
practice for design. Rolled and welded sections
BS 5950-3.1:1990 Design in composite construction. Code of practice
for design of simple and continuous composite beams
BS 5950-4:1994 Structural use of steelwork in building. Code of
practice for design of composite slabs with profiled steel sheeting
BS 5950-6:1995 Structural use of steelwork in building. Code of
practice for design of light gauge profiled steel sheeting
BS 5950-8: 2003 Code of practice for fire resistant design
BSI

- 12 BS EN 1991-1-1:2002 Eurocode 1. Actions on structures. General actions. Densities, self-weight, imposed loads for buildings
BSI
- 13 BS EN 1993-1-3:2006 Eurocode 3. Design of steel structures. General rules. Supplementary rules for cold-formed members and sheeting
BSI
- 14 BS EN 1994-1-1:2004 Eurocode 4. Design of composite steel and concrete structures. General rules and rules for buildings
BSI
- 15 BS 882:1992 Specification for aggregates from natural sources for concrete
BSI
- 16 BS EN 206-1:2000 Concrete. Specification, performance, production and conformity
BSI
- 17 BS 8500-1:2006 Concrete. Complementary British Standard to BS EN 206-1. Method of specifying and guidance for the specifier
BSI.
- 18 BS 8204-2:2003 Screeds, bases and in situ floorings. Concrete wearing surfaces. Code of practice
BSI
- 19 Concrete industrial ground floors - A guide to their design and construction. Third Edition (TR34)
The Concrete Society, 2003
- 20 AD 163: Provision for water vapour release in composite slabs
Advisory Desk, in New Steel Construction, Vol 2 (6), December 1994
- 21 BS 5606: 1990 Guide to accuracy in building
BSI
- 22 BS 4483:2005 Steel fabric for the reinforcement of concrete. Specification.
BSI
- 23 BS 4449:2005 Steel for the reinforcement of concrete. Weldable reinforcing steel. Bar, coil and decoiled product. Specification.
BSI
- 24 BS EN 1992-1-1:2004 Eurocode 2: Design of concrete structures. General rules and rules for buildings
BSI
- 25 BS 8666:2005 Scheduling, dimensioning, bending and cutting of steel reinforcement for concrete. Specification.
BSI
- 26 BOND, A.J., HARRISON T., BROOKER O., MOSS R., NARAYANAN, R. and WEBSTER, R.
How to design concrete structures using Eurocode 2 (CCIP-006)
The Concrete Centre, 2007

- 27 BS EN 14889 Fibres for concrete:.
BS EN 14889-1:2006 Steel fibres. Definitions, specifications and conformity.
BS EN 14889-2:2006 Polymer fibres. Definitions, specifications and conformity
BSI
- 28 Cracking in composite/corrugated metal decking floor slabs (CAS13)
The Concrete Society, 2003
- 29 JOHNSON, R.P. and ANDERSON, D.
Designer's Guide to BS EN 1994-1-1
Eurocode 4: Design of composite steel and concrete structures
Part 1.1 General rules and rules for buildings
Thomas Telford, 2004
- 30 BS 8110-1:1997 Structural use of concrete. Code of practice for design and construction
BSI
- 31 BS EN 1994-1-2:2005 Eurocode 4. Design of composite steel and concrete structures. General rules. Structural fire design
BSI
- 32 NA to BS EN 1994-1-2:2005 UK National Annex to Eurocode 4. Design of composite steel and concrete structures. General rules. Structural fire. design
BSI
- 33 SIMMS, W.I., KIRBY, B.R., BAILEY, C.G. and BURGESS, I.W.
Steel building design: Fire resistance design (P375)
The Steel Construction Institute, 2008.
- 34 Backpropping Flat Slabs by Eur Ing Pallett Bsc Eng FICE FCS – PFP/136 (23/08/04): Pallett Temporary Works Ltd
- 35 McKENNA, P.D. and LAWSON, R.M.
Interfaces: Design of steel framed buildings for service integration (P166)
The Steel Construction Institute, 1997
- 36 OGDEN, R.G.
Interfaces: Curtain wall connections to steel frames (P101)
The Steel Construction Institute, 1992
- 37 WAY, A.G. and COUCHMAN, G.H.
Acoustic Detailing for Steel Construction (P372)
The Steel Construction Institute, 2008
- 38 DEPARTMENT OF LOCAL GOVERNMENT AND COMMUNITIES
The Building Regulations 2000
Approved Document E: Resistance to the passage of sound
The Stationery Office, 2003
- 39 Part E Robust Details Handbook 3rd edition
Robust Details Ltd, 2007
- 40 Guidance for the design of steel-fibre-reinforced concrete (TR63)
The Concrete Society, 2007
- 41 Guidance on the use of macro-synthetic fibre reinforced concrete (TR65)
The Concrete Society, 2007

- 42 MULLETT, D.L.
Composite floor systems
Blackwell Science and The Steel Construction Institute, 1998
- 43 LAWSON, R.M.
Design of composite slabs and beams with steel decking (P055)
The Steel Construction Institute, 1989
- 45 AD 150, Composite floors - wheel loads from forklift trucks
Advisory Desk, in New Steel Construction, Vol 1(7), Dec 1993
- 46 LAWSON, R.M.
Commentary on BS 5950: Part 3: Section 3.1 'Composite Beams' (P078)
The Steel Construction Institute, 1990
- 47 BS EN 1993-1-1:2005 Eurocode 3. Design of steel structures. General
rules and rules for buildings
BSI
- 48 NETHERCOT, D.A. and LAWSON, R.M.
Lateral stability of steel beams and columns (P093)
The Steel Construction Institute, 1992
- 49 BS EN 1990:2002 Eurocode. Basis of structural design
BSI
- 50 LAWSON, R.M. and HICKS, S.J.
Design of beams with large web openings for services (P355)
The Steel Construction Institute, to be published 2009
- 51 SMITH, A.L., HICKS, S.J. and DEVINE, P.J.
Design of floors for vibration: A new approach (P354)
The Steel Construction Institute, 2007
- 52 NEWMAN, G.M., ROBINSON, J.T. and BAILEY, C.G.
A new approach to multi-storey steel-framed buildings. Second Edition
(P288)
The Steel Construction Institute, 2006.
- 53 NEWMAN L C, DOWLING, J.J. and SIMMS, W I.
Structural fire design: Offsite applied thin film intumescent
coatings. Second Edition (P160)
The Steel Construction Institute, 2005.
- 54 RT1187: Guidance on the fire protection of beams with web openings The
Steel Construction Institute, 2005.
- 55 BS 476-21:1987 Fire tests on building materials and structures. Methods
for determination of the fire resistance of loadbearing elements of
construction
BSI
- 56 NEWMAN, G.M. and LAWSON, R.M.
Fire resistance of composite beams (P109)
The Steel Construction Institute, 1991
- 57 HICKS, S.J.
Strength and ductility of headed stud connectors welded in modern
profiled steel sheeting,
The Structural Engineer, Vol. 85(10), May 2007, pp 32-38

- 58 AD 192, Transverse reinforcement in composite T-beams
Advisory Desk, in *New Steel Construction*, Vol 5 (1), Feb/Mar 1997
- 59 AD 266, Shear connection in composite beams
Advisory Desk, in *New Steel Construction*, Vol 11 (4), July 2003
- 60 Fire protection for structural steel in buildings (4th edition)
ASFP/ FTSG/ SCI, 2007.
- 61 CIMSTEEL
Design for Construction
The Steel Construction Institute, 1997
- 62 AD 174, Shear connection along composite edge beams
Advisory Desk, in *New Steel Construction*, Vol 3 (3), June 1995
- 63 BS EN 12350-1:2000 Testing fresh concrete. Sampling
BSI
- 64 Cracking: power trowelled concrete for floor slabs (CAS8)
The Concrete Society, 2003
- 65 BS 8203: 1996 Code of Practice for installation of resilient floor coverings.
- 66 Composite concrete slabs on steel decking - GCG5 (CS161)
The concrete Society, 2008
- 67 The Manual and Advisory Safety Code of Practice for concrete pumping
BCPA, 1990
- 68 Guide to steel erection in windy conditions (ref 39/05)
BCSA, 2004
- 69 Guide to the erection of multi-storey buildings (ref 42/06)
BCSA, 2006
- 70 Good construction practice for composite slabs
Publication No. 73, European Convention for Constructional Steelwork
Technical Committee 7 - Working Group 7.6
ECCS, 1993
- 71 National Structural Steelwork Specification for Building Construction (5th edition)
BCSA and SCI, 2007
- 72 Guidance Note GS28: Safe Erection of Structures
HMSO, 1984 (currently withdrawn, awaiting update)
- 73 Health and safety in construction (3rd Edition))
HSG 150, HSE Books, 2006
- 74 CORUS
Slimdek Manual (<http://www.corusconstruction.com>)
- 75 MULLETT, D.L.
Design of RHS *Slimflor*[®] edge beams (P169)
The Steel Construction Institute, 1997
- 76 LAWSON, R.M., MULLETT, D.L., and RACKHAM, J.W.
Design of Asymmetric *Slimflor*[®] Beams using deep composite decking (P175)
The Steel Construction Institute, 1997

- 77 MULLETT, D.L., and LAWSON, R.M.
Design of *Slimflor*[®] fabricated beams using deep composite decking
(P248)
The Steel Construction Institute, 1999
- 78 Slim Floor Integrated Design Software (SIDS)
Corus (<http://www.corusconstruction.com>)
- 79 NETHERCOT, D. A., SALTER, P. R. and MALIK, A. S.
Design of members subject to combined bending and torsion (P057)
The Steel Construction Institute, 1989
- 80 Lindaport International, Brackenbeck Road, Bradford, West Yorkshire
BDN 2NF
- 81 WAY, A.J.
Guidance on meeting the robustness requirements in Approved Document
A (P341)
The Steel Construction Institute, 2005
- 82 BCSA Guide to the Installation of Deep Decking
Publication number 44/07
BCSA, 2007



MCRMA
18 MERE FARM ROAD
PRENTON
WIRRAL
CHESHIRE
CH43 9TT

TEL: 0151 652 3846
FAX: 0151 653 4080
www.mcrma.co.uk



Steel Knowledge

THE STEEL CONSTRUCTION INSTITUTE
SILWOOD PARK
ASCOT
BERKSHIRE
SL5 7QN

TEL: 01344 636525
FAX: 01344 636570
www.steel-sci.org